

---

**IMPORTANT  
READ CAREFULLY BEFORE USE  
KEEP SAFE FOR LATER REFERENCE**



# **TRANSLATION OF THE ORIGINAL OPERATING INSTRUCTIONS**

**EN**

## **ELECTRIC BICYCLES**

Comfort, Escaro Comp 8, Escaro Cross, EscaroPro,  
Quadriga Cityhopper, Quadriga CX, Quadriga Cross,  
Quadriga Plus, Quadriga

KB065-VAKxxx, KB065-VBKxxx, KB065-VCKxxx, KB066-VAFxxx, KB066-VBFxxx, KB066-VCFxxx,  
KB068.VAFxxx, KB068-VARxxx, KB069-VAFxxx, KB070-VAKxxx, KB070-VBKxxx, KB076-VAFxxx,

Copyright

© ZEG Zweirad-Einkaufs-Genossenschaft eG

Distribution or reproduction of these operating instructions and utilisation or communication of their content is prohibited unless expressly approved. Any infringement will render the offender liable for compensation. All rights reserved in the event that a patent, utility model or industrial design is registered.

# Data sheet

Surname, first name of the purchaser:

---

Date of purchase:

---

Model:

---

Frame number:

---

Type number:

---

Unladen weight (kg):

---

Tyre size:

---

Recommended tyre pressure (bar)\*: front:                      rear:

---

Wheel circumference (mm):

---

Company stamp and signature:

\*After a tyre change, refer to the tyre markings for the permitted tyre pressures and make sure that they are observed. The recommended tyre pressure must not be exceeded.

# Table of contents

<b>1</b>	<b>About these instructions</b>	<b>7</b>
1.1	Manufacturer	7
1.2	Laws, standards and directives	8
1.3	Other valid documents	8
1.4	Subject to change	9
1.5	Language	9
1.6	For your safety	11
1.6.1	Instruction, training and customer service	11
1.6.2	Basic safety notes	12
1.6.3	Warnings	12
1.6.4	Safety markings	13
1.7	For your information	13
1.7.1	Instructions for actions	13
1.7.2	Information on the type plate	14
1.7.3	Language conventions	15
1.8	Type plate	17
1.9	Identifying	18
1.9.1	Operating instructions	18
1.9.2	Bicycle	18
<b>2</b>	<b>Safety</b>	<b>20</b>
2.1	Requirements for the rider	20
2.2	Hazards for vulnerable groups	20
2.3	Personal protective equipment	20
2.4	Proper use	21
2.4.1	City and trekking bicycle	21
2.5	Improper use	22
2.5.1	City and trekking bicycle	22
2.6	Duty to take care	23
2.6.1	Rider	23
<b>3</b>	<b>Description</b>	<b>24</b>
3.1	Overview	24
3.2	Handlebars	25
3.3	Wheel and fork	27
3.3.1	Valve	27
3.4	Brake system	29
3.5	Electric drive system	31
3.6	Drive system	31

3.6.1	Battery	33
3.6.1.1	Operating and charge status indicator	34
3.6.2	Operating element with display	35
3.6.2.1	Level of assistance	36
3.6.2.2	Current speed	36
3.6.2.3	System message	36
<b>4</b>	<b>Technical data</b>	<b>37</b>
<b>5</b>	<b>Transportation, storage and assembly</b>	<b>39</b>
5.1	Transportation	39
5.1.1	Using the transport securing system	41
5.2	Storing	41
5.2.1	Break in operation	42
5.2.1.1	Preparing a break in operation	43
5.2.1.2	Taking out of operation	43
5.3	Assembly	44
5.3.1	Required tools	44
5.3.2	Unpacking	45
5.3.3	Scope of delivery	45
5.3.4	Commissioning	46
5.3.4.1	Checking the battery	48
5.3.4.2	Checking the stem and handlebars	49
5.3.5	Sale of the bicycle	50
<b>6</b>	<b>Before the first ride</b>	<b>51</b>
6.1	Adjusting the saddle	51
6.1.1	Adjusting the saddle tilt	51
6.1.2	Determining the seat height	52
6.1.3	Adjusting the seat height with quick release	53
6.1.4	Setting the height-adjustable seat post	55
6.1.4.1	Lowering the saddle	55
6.1.4.2	Raising the saddle	55
6.1.5	Adjusting the seat position	56
6.2	Setting the handlebars	57
6.2.1	Adjusting the handlebar height	58
6.2.2	Turning the handlebars to the side	59
6.2.2.1	Checking the clamping force of the quick releases	60
6.2.2.2	Adjusting the quick release clamping force	60
6.3	Adjusting the brake lever	60
6.3.1	Adjusting the pressure point on a Magura brake lever	60

## Table of contents

---

6.3.2	Adjusting the grip distance	61
6.3.2.1	Adjusting the grip distance on a Magura brake lever	62
6.4	Retracting brake linings	63
<b>7</b>	<b>Operation</b>	<b>64</b>
7.1	Before each ride	66
7.2	Check list before each ride	67
7.3	Using the kickstand	68
7.4	Battery	69
7.4.1	Integrated battery	71
7.4.1.1	Removing the integrated battery	71
7.4.1.2	Inserting the integrated battery	71
7.4.2	Charging the battery	72
7.4.3	Waking the battery	74
7.5	Electric drive system	75
7.5.1	Switching on the drive system	75
7.5.2	Switching off the drive system	75
7.6	Operating element with display	76
7.6.1	Selecting the level of assistance	76
7.7	Brakes	76
7.7.1	Using the brake	77
7.8	Gear shift	78
7.8.1	Using derailleur gears	78
7.9	Brake	79
7.9.1	Using the brake lever	83
7.9.2	Using the back-pedal brake	83
<b>8</b>	<b>Maintenance</b>	<b>84</b>
8.1	Cleaning and servicing	86
8.1.1	After every ride	86
8.1.1.1	Cleaning the suspension fork	86
8.1.1.2	Cleaning the rear frame damper	86
8.1.1.3	Cleaning the pedals	86
8.1.2	Basic cleaning	87
8.1.2.1	Cleaning the frame	88
8.1.2.2	Cleaning the stem	88
8.1.2.3	Cleaning the rear frame damper	88
8.1.2.4	Cleaning the wheel	88
8.1.2.5	Cleaning the drive elements	89
8.1.2.6	Cleaning the chain	89

---

8.1.2.7	Cleaning the battery	90
8.1.2.8	Cleaning the drive unit	90
8.1.2.9	Cleaning the display	91
8.1.2.10	Cleaning the brake	91
8.1.3	Servicing	92
8.1.3.1	Servicing the frame	92
8.1.3.2	Servicing the stem	92
8.1.3.3	Servicing the fork	92
8.1.3.4	Servicing the drive elements	92
8.1.3.5	Servicing the pedal	92
8.1.3.6	Servicing the chain	92
8.1.3.7	Servicing the drive elements	93
8.2	Maintenance	94
8.2.1	Wheel	94
8.2.2	Brake system	95
8.2.3	Electrical cables and brake cables	95
8.2.4	Gear shift	95
8.2.5	Stem	96
8.2.6	Checking the chain and belt tension	96
8.2.7	USB port	97
8.2.8	Suspension fork	97
8.3	Service	98
8.4	Adjusting and repairing	100
8.4.1	Use original parts and lubricants only	100
8.4.2	Wheel quick release	101
8.4.2.1	Clamping the quick release	102
8.4.3	Adjusting the tyre pressure	104
8.4.3.1	Dunlop valve	104
8.4.3.2	Presta valve	105
8.4.3.3	Schrader valve	106
8.4.4	First aid for system messages	107
8.4.4.1	First aid	107
8.4.4.2	Specific error eradication	108
8.5	Accessories	109
8.5.1	Child seat	110
8.5.2	Bicycle trailer	111
8.5.3	Pannier rack	112

<b>9</b>	<b>Recycling and disposal</b>	<b>114</b>
<b>10</b>	<b>Appendix</b>	<b>116</b>
10.1	EC declaration of conformity	116
10.2	Parts list	117
10.3	Table of figures	120
10.4	Subject index	123



# 1

## About these instructions

Read these operating instructions before commissioning the bicycle to ensure you use all the functions correctly and safely. The operating instructions are not a substitute for personal instruction by the supplying specialist dealer. The operating instructions are a component part of the bicycle. Therefore, if it is re-sold at a later time, they must be handed over to the subsequent owner.

These operating instructions are mainly directed at the rider and operator of the cycle. In general, they are technical laypersons.



Text passages which are expressly intended for specialist staff (e.g. bicycle mechanics) are clearly marked with a tool symbol.

Staff at all specialist dealers have specialist training and qualifications, and are therefore capable of identifying risks and preventing hazards which may arise during maintenance, servicing and repairs on the bicycle. Information for specialist staff does not require non-professionals to take any action.

### 1.1

## Manufacturer

The manufacturer of the bicycle is:

KETTLER Alu-Rad GmbH  
Longericher Straße 2  
50739 Köln, Germany

Tel.: +49 6805 6008-0  
Fax: +49 6805 6008-3098  
E-mail: [info@kettler-alu-rad.de](mailto:info@kettler-alu-rad.de)  
Internet: [www.kettler-alu-rad.de](http://www.kettler-alu-rad.de)

## 1.2 **Laws, standards and directives**

These operating instructions comply with the essential requirements from:

- the Machinery Directive 2006/42/EC,
- Electromagnetic Compatibility Directive 2014/30/EU,
- EN ISO 12100:2010 Safety of machinery – General principles of design – Risk assessment and reduction,
- EN 15194:2015, Cycles – Electrically power assisted cycles – EPAC bicycles,
- EN ISO 4210, Cycles – Safety requirements for bicycles
- EN 11243:2016, Cycles – Luggage carriers for bicycles – Requirements and test methods,
- EN 82079-1:2012, Preparation of instructions for use – Structuring, content and presentation – Part 1: General principles and detailed requirements,
- EN ISO 17100:2016-05, Translation Services – Requirements for translation service.

## 1.3 **Other valid documents**

These operating instructions are only complete in conjunction with the other valid documents.

The following document applies for this product:

- Charger operating instructions.

No other information is also applicable.

The constantly updated lists of approved accessories and parts are available to specialist dealers.

## **1.4 Subject to change**

The information contained in these operating instructions are the approved technical specifications at the time of printing. Any significant changes are included in a new issue of the operating instructions.

You will find any modifications to these operating instructions at:  
[www.kettler-alu-rad.de/de/de/index/service/anleitung](http://www.kettler-alu-rad.de/de/de/index/service/anleitung)

## **1.5 Language**

The original operating instructions are written in German. A translation is not valid without the original operating instructions.

## 1.6 For your safety

The safety concept of the bicycle comprises four elements:

- rider and/or operator instruction, and bicycle maintenance and repair by the specialist dealer,
- the chapter on general safety,
- the warnings in these instructions and
- the safety marking on the type plates.

### 1.6.1 Instruction, training and customer service

The supplying specialist dealer will provide customer service. Contact details can be found on the back page of these operating instructions and in the data sheet. If you are unable to contact your specialist dealer, you will find other specialist dealers to attend to your customer service needs on [www.kettler-alu-rad.de](http://www.kettler-alu-rad.de).



The specialist dealer authorised to perform repairs and maintenance work receives regular training.

The rider or the operator of the bicycle will be instructed in person on the bicycle functions when the supplying specialist dealer hands over the bicycle, if not before. This instruction particularly covers the bicycle's electrical functions and correct use of the charger.

Each rider to whom this bicycle is provided must receive instruction on the bicycle's functions. The operating instructions must be submitted to each rider in printed form and must be acknowledged and adhered to.

## 1.6.2 Basic safety notes

These operating instructions have a chapter with general safety notes. You can distinguish this chapter as it has a grey background.

## 1.6.3 Warnings

Hazardous situations and actions are marked with warnings. The warnings in these operating instructions are shown as follows:

### SIGNAL WORD

#### Type and source of the danger

Description of the danger and the consequences.

#### ► Measures

The following pictograms and signal words are used in the operating instructions for warnings and information notices:



**DANGER**

Will lead to serious or even fatal injuries if ignored.  
High-risk hazard.



**WARNING**

May lead to serious or even fatal injuries if ignored.  
Medium-risk hazard.



**CAUTION**

May lead to minor or moderate injuries. Low-risk hazard.

**NOTICE**

May lead to material damage if ignored.

Table 1:

Meanings of the signal words

## 1.6.4

### Safety markings

The following safety markings are used on the bicycle's type plates:

---



General warning



Adhere to the instructions for use

---

Table 2:

### Safety markings on the product

## 1.7

### For your information

### 1.7.1

#### Instructions for actions

Instructions for actions are structured in accordance with the following pattern:

- ✓ Requirements (optional)
- ▶ Instruction for action
- ⇒ Result of the action (optional)

1.7.2

**Information on the type plate**

Alongside the warnings, the type plates of the products also contain other important information on the bicycle:



only suitable for the road, no off-road riding or jumps

suitable for roads, off-road riding and jumps of up to 15 cm

suitable for rough off-road riding and jumps of up to 61 cm

suitable for rough off-road riding and jumps of up to 122 cm

suitable for the most difficult terrain

Table 3:

**Area of use**



City and trekking bicycle



Child's bicycle / bicycle for young adults



BMX bicycle



Mountain bike



Racing bicycle



Carrier bicycle



Folding bicycle

Table 4:

**Bicycle type**



Read the instructions



Separate collection of electrical and electronic devices



Separate collection of batteries



Must not be thrown into fire (burning prohibited)



Must not be thrown into water (immersed)



Device of protection class II



Only suitable for use indoors



Fuse (device fuse)



EU conformity



Recyclable material

Table 5:

---

**Information on the type plate**

**1.7.3**

**Language conventions**

The bicycle described in these operating instructions may be equipped with alternative components. The equipment of the bicycle is defined by the respective type number [▷ *Table 3, page 14*]. If applicable, the notes *alternative equipment* and *alternative version* make reference to the use of alternative components.

*Alternative equipment* describes additional components which are not necessarily an integral part of every bicycle in these instructions.



*Alternative version* explains the various variants of components if they differ in use.

The following terms are used for better legibility:

Term	Meaning
Operating instructions	Original operating instructions or translation of the original operating instructions
Bicycle	Electric motor driven cycle
Motor	Drive motor

Table 6:

#### Simplified terms

The following conventions are used in these operating instructions:

Convention	Use
<i>Italics</i>	Entry in the index
SPACED	Displays on the <i>display screen</i>
[> <i>Example, page numbering</i> ]	Cross references
•	Bulleted lists

Table 7:

#### Conventions

## 1.8 Type plate

The type plate is situated on the *frame*. The type plate features the following information:

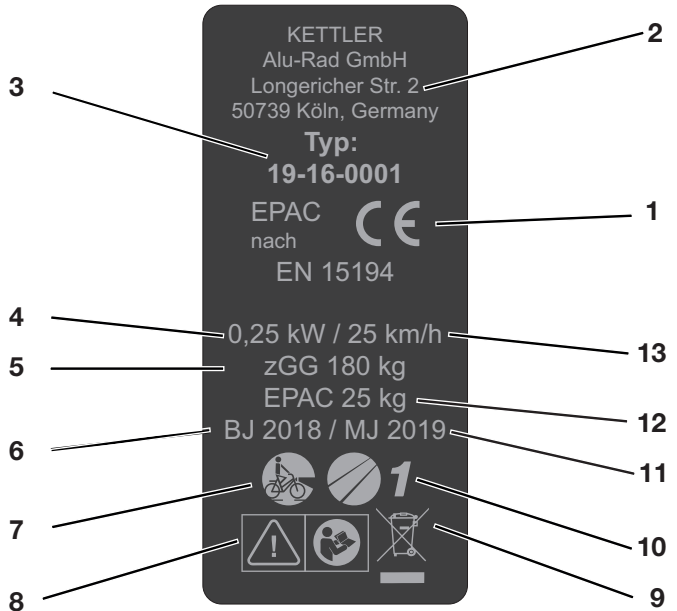

Figure 1:

Type plate, example

- 1 CE marking
- 2 Manufacturer
- 3 Type number
- 4 Nominal continuous power
- 5 Permitted total weight
- 6 Year of manufacture
- 7 *Bicycle type*
- 8 *Safety instructions*
- 9 *Disposal instruction*
- 10 *Area of use*
- 11 Model year
- 12 Weight of the ready-to-ride bicycle
- 13 Shut-off speed

## 1.9 Identifying

### 1.9.1 Operating instructions

The identification number of these operating instructions is made up of the document number, the version number and the release date. It can be found on the cover page and in the footer.

<b>Identification number</b>	877-00136_1.0_17.09.2018
------------------------------	--------------------------

Table 8:

**Identification number of the operating instructions**

### 1.9.2 Bicycle

These KETTLER operating instructions refer to the *model year* 2019. The production period is from August 2018 to July 2019. They are issued in August 2018.

The operating instructions are a component part of the following bicycles:

<b>Type number</b>	<b>Model</b>	<b>Bicycle type</b>
KU117-VAFD50	2° E Beltdrive	City and trekking bicycle
KU117-VAFD55	2° E Beltdrive	City and trekking bicycle
KU117-VAFD60	2° E Beltdrive	City and trekking bicycle
KU117-VAFT45	2° E Beltdrive	City and trekking bicycle
KU117-VAFT50	2° E Beltdrive	City and trekking bicycle
KU118-VAFD50	2° E Street Beltdrive	City and trekking bicycle
KU118-VAFD55	2° E Street Beltdrive	City and trekking bicycle
KU118-VAFD60	2° E Street Beltdrive	City and trekking bicycle
KU118-VAFT45	2° E Street Beltdrive	City and trekking bicycle
KU118-VAFT50	2° E Street Beltdrive	City and trekking bicycle
KU119-VAFD50	2° E Comp	City and trekking bicycle
KU119-VAFD55	2° E Comp	City and trekking bicycle
KU119-VAFD60	2° E Comp	City and trekking bicycle
KU119-VAFT45	2° E Comp	City and trekking bicycle
KU119-VAFT50	2° E Comp	City and trekking bicycle
KU120-VAFD50	2° E Carbon	City and trekking bicycle
KU120-VAFD55	2° E Carbon	City and trekking bicycle
KU120-VAFD60	2° E Carbon	City and trekking bicycle
KU120-VAFT45	2° E Carbon	City and trekking bicycle
KU120-VAFT50	2° E Carbon	City and trekking bicycle

<b>Type number</b>	<b>Model</b>	<b>Bicycle type</b>
KU121-VAFD46	2° E Compact	City and trekking bicycle
KU159-VAKD50	2° E Comp Street	City and trekking bicycle
KU159-VAKD55	2° E Comp Street	City and trekking bicycle
KU159-VAKD60	2° E Comp Street	City and trekking bicycle
KU159-VAKT45	2° E Comp Street	City and trekking bicycle
KU159-VAKT50	2° E Comp Street	City and trekking bicycle

## 2

### Safety

#### 2.1

#### Requirements for the rider

If there are no legal requirements for riders of electrically power-assisted cycles, we recommend that the rider should be a minimum 14 years of age and have experience with muscle-powered bicycles.

The physical and mental abilities of the rider must be sufficient for riding on public roads.

#### 2.2

#### Hazards for vulnerable groups

The battery and the charger must be kept out of the reach of children.

If the bicycle is used by minors, comprehensive instruction should be provided by or in the presence of the legal guardians. Supervised use should also be scheduled until it is certain that the bicycle is being used as per these operating instructions. Legal guardians hold sole responsibility for determining whether minors are capable of using the bicycle.

#### 2.3

#### Personal protective equipment

We recommend that you wear a suitable safety helmet. We also recommend that you wear typical, long, close-fitting cycling clothing and sturdy footwear.

## 2.4

### Proper use

The bicycle is designed to support a maximum speed of 25 km/h. The bicycle may only be used in a perfect, fully functional condition.

National requirements may apply to the bicycle which differ from the standard equipment. For riding on public roads, some special regulations apply in relation to the driving light, reflectors and other components.

The general laws and the regulations for the prevention of accidents and environmental protection in the respective country of use must be adhered to. All check lists and instructions for actions in these operating instructions must be met. Approved accessories can be installed by specialist staff.

Each bicycle is assigned a bicycle type, which determines its proper use and area of use.

### 2.4.1



### City and trekking bicycle

City and trekking bicycles are designed for daily, comfortable use. They are suitable for riding on public roads.

#### Area of use:



1

Suitable for tarmacked and paved roads.



2

Suitable for tarmacked roads, cycle paths and firm gravel paths and roads, and longer sections with moderate slopes and jumps up to 15 cm.

## 2.5

### Improper use

Failure to adhere to the proper use poses a risk of personal injury and material damage. The bicycle is not suitable for the following uses:

- when the electrical drive system has been manipulated
- when the permitted gross load weight is exceeded
- riding with a damaged or incomplete bicycle
- riding over steps
- riding through deep water
- lending the bicycle to untrained riders
- carrying other people
- riding with excessive luggage
- riding with no hands
- riding on ice and snow
- improper servicing
- improper repair
- tough areas of use, such as professional competitions
- stunt riding or acrobatics.

### 2.5.1



#### City and trekking bicycle

City and trekking bicycles are not sports bicycles. If used for sports, the rider can expect reduced riding stability and diminished comfort.

#### Non-permitted areas of use:



**1**

Never drive off-road or perform jumps.



**2**

Never drive off-road or perform jumps over 15 cm.

## 2.6

### Duty to take care

The safety of the bicycle can only be assured if all the necessary measures are taken.

### 2.6.1

#### Rider

The rider:

- receives instruction before the first ride. They can clarify any questions relating to the operating instructions with the operator or specialist dealer
- wears personal protective equipment.
- assumes all the obligations of the operator in case the bicycle changes hands.

#### Operator

The operator has the duty of care and responsibility for scheduling these measures and checking that they are implemented.

The operator:

- makes these operating instructions available to the rider for the duration of use of the bicycle. If necessary, they translate the operating instructions into a language which the rider understands.
- familiarises the rider with the functions of the bicycle before the first ride. Only riders who have received instruction may be allowed to ride.
- instructs the rider on proper use and the wearing of personal protective equipment.
- only employs specialist staff for maintenance and repair of the bicycle.



### 3 Description

#### 3.1 Overview



**Figure 2:** Bicycle viewed from the right, 2° E Beltdrive used as example

- 1 *Front wheel*
- 2 *Fork*
- 3 *Handlebars*
- 4 *Stem*
- 5 *Frame with integrated display*
- 6 *Seat post*
- 7 *Saddle*
- 8 *Reflector*
- 9 *Rear wheel*
- 10 *Chain*
- 11 *Frame number and type plate*

### 3.2

### Handlebars

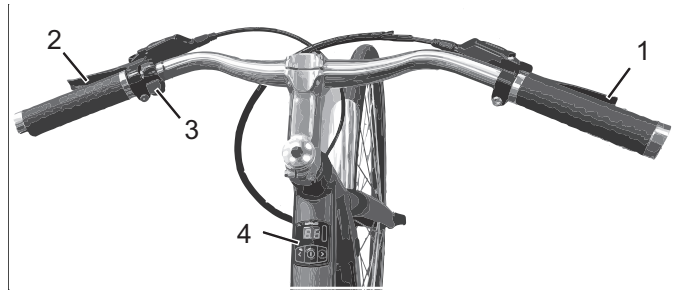

Figure 3:

Detailed view of bicycle from rider position, example

- 1 Rear brake lever
- 2 Front brake lever
- 3 *Bell*
- 4 Integrated display

### 3.3

## Wheel and fork

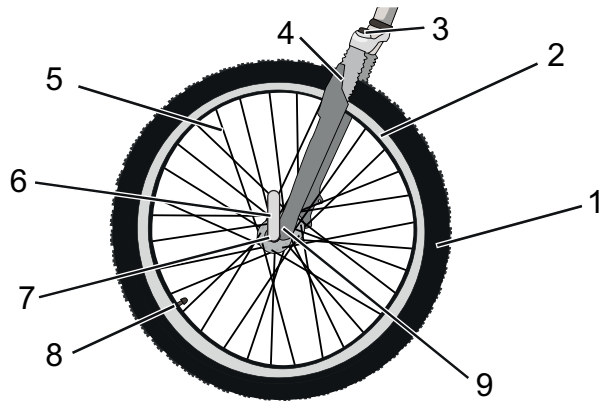

Figure 4:

Components of the wheel – example showing front wheel

- |   |   |
|---|---|
| 1 | Tyre                                    |
| 2 | Rim                                     |
| 3 | Suspension fork head with setting wheel |
| 4 | Fork                                    |
| 5 | Spoke                                   |
| 6 | Quick release                           |
| 7 | Hub                                     |
| 8 | Valve                                   |
| 9 | Fork end of the suspension fork         |

#### 3.3.1

### Valve

Each wheel has a valve. It is used to fill the *tyre* with air. There is a valve cap on each valve. The screw-on valve cap keeps out dust and dirt.

The bicycle either has a classical *Dunlop valve*, a *Presta valve* or a *Schrader valve*.

### **Dunlop valve**



The rider can easily exchange the valve and quickly release the air. The air pressure cannot be measured with this valve.

### **Presta valve**



The presta valve requires a smaller hole in the rim, which is why it is especially suitable for the narrow rims of racing bicycles. The air pressure can be measured with this valve.

### **Schrader valve**



The rider can fill the Schrader valve very easily at a petrol station. The air pressure can be measured with this valve.

### 3.4

## Brake system

The bicycle is equipped with a disc brake.

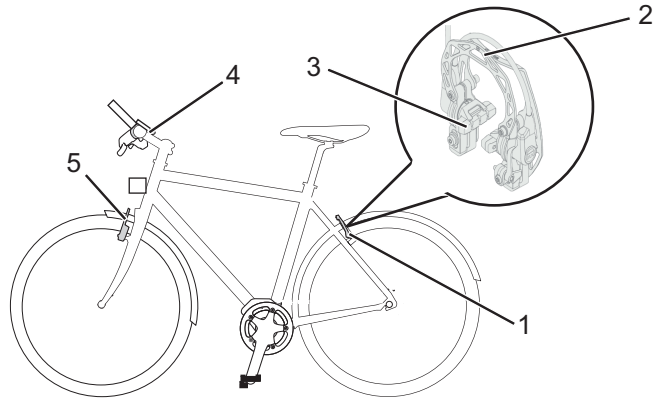

Figure 5:

Rim brake components with details – example: Magura HS22

- 1 Rear wheel rim brake
- 2 Brake booster
- 3 Brake lining
- 4 *Handlebars with brake levers*
- 5 Front wheel rim brake

The rim brake stops the wheel moving when the rider pulls the *brake lever*, causing two brake linings, positioned opposite one another, to be pressed onto the *rims*.

The hydraulic rim brake features a locking lever

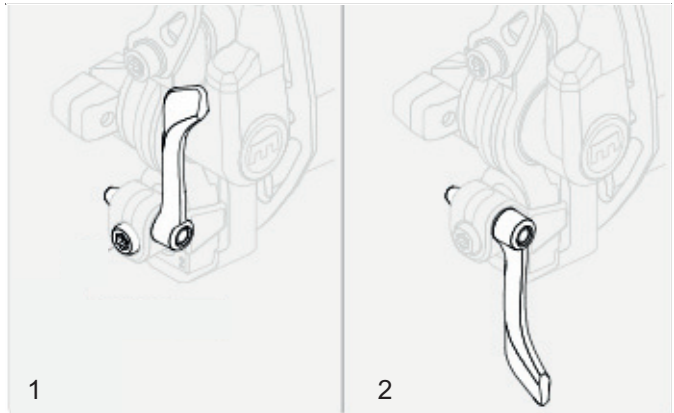

**Figure 6:** *Rim brake locking lever, closed (1) and open (2)*



The rim brake locking lever is not marked with any lettering. Only a specialist dealer may set the rim brake locking lever.

### 3.5 Electric drive system

### 3.6 Drive system

The bicycle is driven by muscle power via the chain drive. The force which is applied by pedalling in the direction of travel, drives the front chain wheel. The chain transmits the force onto the rear chain wheel and then onto the rear wheel.

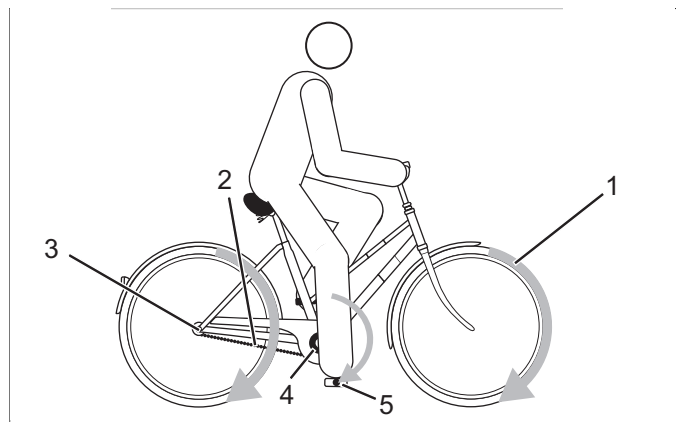
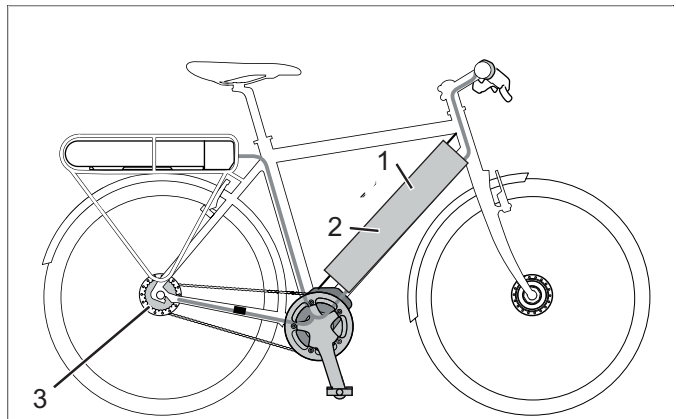

Figure 7:

Diagram of drive system

- 1 Direction of travel
- 2 Chain
- 3 Rear chain wheel
- 4 Front chain wheel
- 5 Pedal

The bicycle also has an integrated, electric drive system. The electric drive system is made up of four components:



**Figure 8:** **Diagram of electric drive system**

- 1 *Operating element* with display
- 2 Integrated battery
- 3 Motor
- a charger which is designed for this battery.

As soon as the required muscle power from the rider pedalling passes a certain level, the motor is activated gently and assists the pedalling motion of the rider. The motor force is determined by the set level of assistance.

The bicycle does not have a separate emergency stop or emergency shut-off button. The drive system can be stopped in case of emergency by removing the *display*.

The motor switches off automatically as soon as the rider no longer pedals, the temperature is outside the permitted range, there is an overload or the shut-off speed of 25 km/h has been reached.



## 3.6.1

**Battery**

The lithium ion battery has an internal electronic protection circuit. It is matched to the charger and the bicycle. The battery temperature is monitored at all times. The battery is safeguarded against deep discharge, overcharging, overheating and short circuit. In case of a risk the battery is switched off automatically by a protective circuit. The battery also switches to sleep mode for self-protection when not used for a longer period.

The service life of the battery can be extended if it is well cared for and, above all, stored at the correct temperatures. Even if the battery is cared for properly, the charge status of the battery reduces as it ages. If the operating time is severely shortened after charging, this is a sign that the battery is spent.

---

<b>Transportation temperature</b>	5 °C–25 °C
<b>Ideal transportation temperature</b>	10 °C–15 °C
<b>Storage temperature</b>	5 °C–25 °C
<b>Ideal storage temperature</b>	10 °C–15 °C
<b>Charging ambient temperature</b>	10 °C–30 °C

---

Table 9:

**Battery technical data**

The bicycle has an integrated battery.

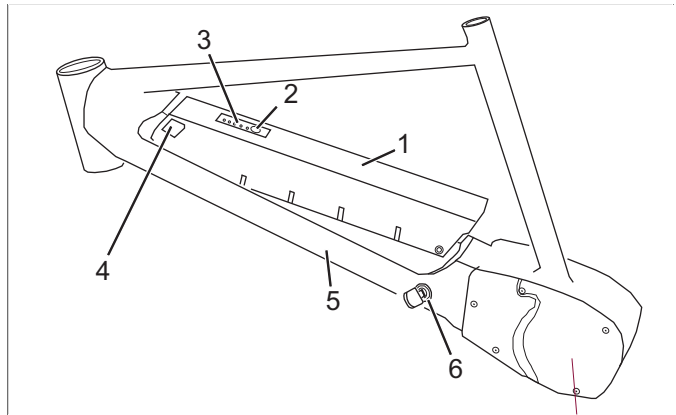

**Figure 9:** Integrated battery details

- 1 Battery housing
- 2 On-Off switch
- 3 Operating and charge status indicator
- 4 Connection cover for charger plug
- 5 Down tube
- 6 Battery lock

### 3.6.1.1 Operating and charge status indicator

The five green LEDs of the operating and charge status indicator indicate the charge status of the battery when the battery is switched on. Each LED represents 20% of the charge status. The charge status of the activated battery is also shown on the *display*.

If the charge status of the battery is below 5%, all the LEDs of the operating and charge status indicator go out. However, the charge status is still shown on the *display*.

### 3.6.2 Operating element with display

The operating element with display controls the drive system and shows journey data.

The bicycle's battery supplies the operating element with display with energy when a sufficiently charged battery is inserted on the bicycle, and the drive system is switched on.

**Storage temperature** 5 °C–25 °C

**Charging ambient temperature** 10 °C–30 °C

**Table 10:** Display technical data

The operating element with display has three buttons and three indicators.

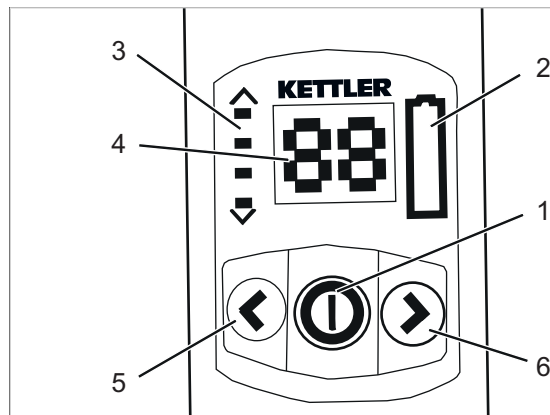

**Figure 10:** Operating element overview

#### Surname

- 1 On-Off button
- 2 Charge status indicator
- 3 Level of assistance indicator
- 4 Speed or system message display
- 5 Down button
- 6 Up button

**Table 11:** Overview of operating element with indicators

**3.6.2.1**

**Level of assistance**

The higher the selected level for assistance, the more the drive system assists the rider when pedalling. There are four levels of assistance available.

**3.6.2.2**

**Current speed**

The current speed is displayed in km/h.

**3.6.2.3**

**System message**

The drive system monitors itself continuously and if an error is detected, it is indicated by a system message. The system may switch off automatically depending on the type of error. There is a table of system messages in the Appendix.

## 4 Technical data

### Bicycle

---

<b>Transportation temperature</b>	5 °C–25 °C
<b>Ideal transportation temperature</b>	10 °C–15 °C
<b>Storage temperature</b>	5 °C–25 °C
<b>Ideal storage temperature</b>	10 °C–15 °C
<b>Operation temperature</b>	5 °C–35 °C
<b>Working environment temperature</b>	15 °C–25 °C
<b>Charging temperature</b>	10 °C–30 °C
<b>Power output/system</b>	250 W (0.25 kW)
<b>Shut-off speed</b>	25 km/h

---

**Table 12:** Bicycle technical data

### Battery

---

<b>Transportation temperature</b>	5 °C–25 °C
<b>Ideal transportation temperature</b>	10 °C–15 °C
<b>Storage temperature</b>	5 °C–25 °C
<b>Ideal storage temperature</b>	10 °C–15 °C
<b>Charging ambient temperature</b>	10 °C–30 °C

---

**Table 13:** Battery technical data

### Display

Storage temperature	5 °C–25 °C
Charging ambient temperature	10 °C–30 °C

Table 14:

#### Display technical data

### Emissions

A-weighted emission sound pressure level	< 70 dB(A)
Total vibration level for the hands and arms	< 2.5 m/s <sup>2</sup>
Highest effective value of weighted acceleration for the entire body	< 0.5 m/s <sup>2</sup>

Table 15:

#### Emissions from the bicycle\*

\*The safety requirements as per Electromagnetic Compatibility Directive 2014/30/EU have been met. The bicycle and the charger can be used in residential areas without restriction.

### Tightening torque

Axle nut tightening torque	35 Nm - 40 Nm
Handlebars clamping screw maximum tightening torque*	5 Nm - 7 Nm

Table 16:

#### Tightening torque values

\*if there is no other data on the component

## 5 Transportation, storage and assembly

### 5.1 Transportation



#### CAUTION

#### Crash caused by unintentional activation

There is a risk of injury if the drive system is activated unintentionally.

- ▶ Remove the battery before the bicycle is transported.



#### CAUTION

#### Risk of fire and explosion due to high temperatures

Excessively high temperatures damage the batteries. The batteries may self-ignite and explode.

- ▶ Never expose the battery to sustained direct sunlight.



#### CAUTION

#### Oil leak if no transport securing device

The brake securing device prevents the brakes from being applied accidentally during transport. This could cause irreparable damage to the brake system or an oil leak, which will harm the environment.

- ▶ Never pull the brake lever when the wheel has been dismantled.
- ▶ Always use the transport securing system when transporting dismantled wheels.

#### NOTICE

If the bicycle is lying flat, oil and grease may leak from the bicycle.

If the shipping box with a bicycle is lying flat or on one end, it does not provide the *frame* and the wheels with adequate protection from damage.

- ▶ Only transport the bicycle in an upright position.

**NOTICE**

Bicycle rack systems which secure the bicycle standing on its head by the *handlebars* or *frame*, generate inadmissible forces on the components during transportation. This can cause the supporting parts to break.

- ▶ Never use bicycle rack systems which secure the bicycle standing on its head by the *handlebars* or *frame*.

---

- ▶ Take into account the ready-to-use bicycle's weight when transporting it.
- ▶ Remove the *display* and the battery before transportation of the bicycle.
- ▶ Protect the electrical components and connections on the bicycle from the elements with suitable protective covers.
- ▶ Remove accessories, for example drinking bottles, before transportation of the bicycle.
- ▶ When transporting by car, you must use a suitable bicycle rack system.



The specialist dealer will advise you on how to select a suitable rack system properly and how to use it safely.

- ▶ Transport the bicycle in a dry, clean place where it is protected from direct sunlight.



When shipping the bicycle, we recommend that you have the bicycle partially dismantled in the proper manner and packaged by the specialist dealer.



## 5.1.1

**Using the transport securing system**

- ▶ Insert the transport securing devices between the brake linings.
- ⇒ The transport securing device is squeezed between the two linings.

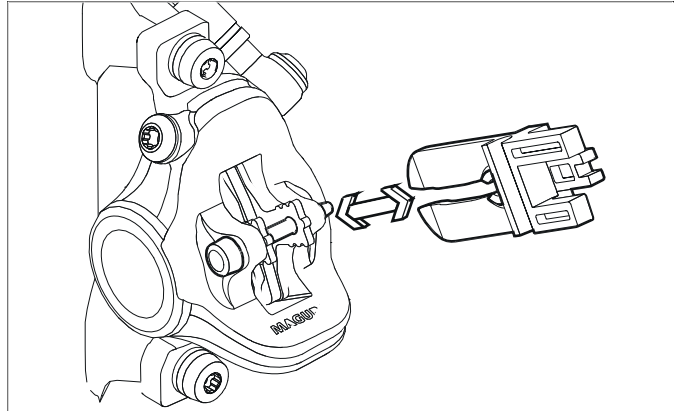

Figure 11:

Fastening the transport securing device

## 5.2

**Storing****Risk of fire and explosion due to high temperatures**

Excessively high temperatures damage the battery. The battery may self-ignite and explode.

- ▶ Protect battery against heat
- ▶ Never expose the battery to sustained direct sunlight.

**NOTICE**

If the bicycle is lying flat, oil and grease may leak from the bicycle.

If the shipping box with a bicycle is lying flat or on one end, it does not provide the *frame* and the wheels with adequate protection from damage.

- ▶ Only store the bicycle in an upright position.

- ✓ If the bicycle features a hydraulic seat post, fix only the lower seat post or the frame into a fitting stand to prevent damage to the upper seat post and the seat post lever.
- ✓ Never place a bicycle with a hydraulic seat post upside down on the floor; otherwise you, will damage the seat post lever.
- ✓ Store the bicycle, battery and charger in a dry and clean place.

---

<b>Storage temperature</b>	5 °C–25 °C
<b>Ideal storage temperature</b>	10 °C–15 °C

---

Table 17:

**Storage temperature for the battery, the bicycle and the charger**

### 5.2.1

### Break in operation

---

#### NOTICE

The battery discharges when it is not used. This can cause damage to the battery.

- ▶ The battery has to be recharged every 8 weeks.
- 

#### NOTICE

The battery may become damaged if it is connected permanently to the charger.

- ▶ Do not connect the battery to the charger permanently.
- 

#### NOTICE

The internal battery in the display discharges when it is not used. This can cause it to be irreparably damaged.

- ▶ Charge the internal battery in the display every 3 months for at least 1 hour.
- 

If the bicycle is to be removed from service for longer than four weeks, e.g. in winter, a break in operation has to be prepared.

### 5.2.1.1

#### **Preparing a break in operation**

- ✓ Remove the battery from the bicycle.
- ✓ Charge the battery to around 60% (three to four LEDs of the charge status indicator light up).
- ✓ The bicycle has to be cleaned with a damp cloth and preserved with wax spray. Never wax the friction surfaces of the brake.
- ✓ Before longer periods without use, it is recommendable to have your specialist dealer carry out servicing and basic cleaning and apply preservative agent.

### 5.2.1.2

#### **Taking out of operation**

- ▶ Store the bicycle, battery and charger in a dry and clean environment.
- ▶ Charge the internal battery in the display every 3 months for at least 1 hour.
- ▶ Check the charge status of the battery after 8 weeks. If only one LED of the charge status indicator lights up, recharge the battery to around 60%.

## 5.3

## Assembly



### Crushing caused by unintentional activation

There is a risk of injury if the drive system is activated unintentionally.

- ▶ Remove the battery if the battery is not absolutely necessary for assembly.



- ✓ Assemble the bicycle in a clean and dry environment.
- ✓ The working environment temperature should be between 15 °C and 25 °C.

**Working environment temperature**

15 °C–25 °C

Table 18:

### Working environment temperature

- ✓ If a fitting stand is used, it must be approved for a maximum weight of 30 kg.
- ✓ To reduce the weight, we recommend that you always disconnect the battery from the bicycle for the duration of use of the fitting stand.

### 5.3.1

### Required tools

The following tools are required to assemble the bicycle:

- Knife
- Hexagon socket spanner 2 (2.5 mm, 3, mm 4 mm, 5 mm, 6 mm and 8 mm)
- Torque wrench with working range between 5 and 40 Nm
- Twelve-point square socket T-25
- Ring spanner (8 mm, 9 mm, 10 mm, 13 mm, 14 mm and 15 mm) and
- Cross, flat head and ordinary screwdriver.

### 5.3.2

## Unpacking



### Hand injuries caused by cardboard packaging

The shipping carton is closed with metal staples. There is a risk of puncture wounds and cuts when unpacking and crushing the packaging.

- ▶ Wear suitable hand protection.
- ▶ Remove the metal staples with pliers before the shipping carton is opened.

The packaging material consists mainly of cardboard and plastic film.

- ▶ The packaging has to be disposed of in accordance with the regulations of the authorities.

### 5.3.3

## Scope of delivery

The bicycle was completely assembled in the factory for test purposes and then dismantled for transportation.

The bicycle is 95–98% pre-assembled. The scope of delivery includes:

- the pre-assembled bicycle
- the front wheel
- the pedals
- quick release (optional)
- the charger
- the operating instructions.

The battery is supplied separately from the bicycle.

### 5.3.4

## Commissioning



### Fire and explosion caused by incorrect charger

Batteries which are charged with an unsuitable charger, may become internally damaged. This may result in fire or an explosion.

- ▶ Only ever use the battery with the supplied charger.
- ▶ Mark the supplied charger and these operating instructions clearly to prevent mix-ups – with the bicycle *frame number* or *type number*, for example.

Since initial commissioning of the bicycle requires special tools and specialist knowledge, only trained specialist staff may perform initial commissioning.

Experience has shown that a bicycle which has not yet been sold, is spontaneously handed to consumers as soon as it appears ready to ride.

- ▶ For this reason, every bicycle must be prepared, so that it is fully ready for use immediately after being assembled.
- ▶ Staff should work through the initial commissioning check list to prepare the bicycle, so that it is ready to ride.

### Initial commissioning check list

<input type="checkbox"/>	Check the battery
<input type="checkbox"/>	The battery is supplied partially charged. Fully charge the battery to ensure full power
<input type="checkbox"/>	Mount the wheels, quick release and pedals.
<input type="checkbox"/>	Re-adjust the quick release clamping force if necessary.
<input type="checkbox"/>	Thoroughly degrease the brake discs in disc brakes or the brake sides and linings in rim brakes with brake cleaner or spirit.
<input type="checkbox"/>	Place handlebars, stem and saddle in the functional position and check they are firmly in place.
<input type="checkbox"/>	Check all the components to make sure that they are firmly in place. Check all the settings and the tightening torque on the axle nuts.
<input type="checkbox"/>	<p>Check the entire cable harness to make sure that it is routed properly:</p> <ul style="list-style-type: none"> <li>• You must prevent the cable harness from coming into contact with moving parts.</li> <li>• The cable routes must be smooth and free from sharp edges.</li> <li>• Moving parts must not apply any pressure or tension to the cable harness.</li> </ul>
<input type="checkbox"/>	Check the drive system, the light equipment and the brakes to make sure that they are fully functional and effective.
<input type="checkbox"/>	Adjust the headlight.
<input type="checkbox"/>	Set the drive system has to the national language and the appropriate system of measurement.
<input type="checkbox"/>	Check the software version of the drive system and update it as necessary.
<input type="checkbox"/>	Take a test drive to check the brake system, gear shift and the electric drive system.

#### 5.3.4.1

### Checking the battery



#### Risk of fire and explosion due to faulty battery

The safety electronics on damaged or faulty batteries may fail. The residual voltage can cause a short circuit. The batteries may self-ignite and explode.

- ▶ Never charge a defective battery.

The battery needs to be checked before it is charged for the first time.

- ▶ Press the *On-Off button (battery)*.

⇒ If none of the LEDs on the operating and charge status indicator light up, the battery may be damaged.

⇒ The battery can be charged if at least one of the LEDs on the operating and charge status indicator is fully lit up, but not if all of them are.

- ▶ Once the battery has been charged, insert the battery on the bicycle.



**5.3.4.2****Checking the stem and handlebars****Checking connections**

▶ Stand in front of the bicycle to check whether the handlebars, stem and fork shaft are firmly attached to one another. Clamp the front wheel between your legs. Grasp the handlebar grips. Try to twist the handlebars towards the front wheel.

⇒ The stem must not move or twist.

**Firm hold**

▶ Place your entire body weight on the handlebars with the quick release lever closed to check that the stem is firmly in place.

⇒ The handlebars shaft must not move downwards in the fork shaft.

▶ If the handlebars shaft should move in the fork shaft, increase the quick release lever tensioning. To do so, turn the knurled nut slightly in a clockwise direction with the quick release lever open.

▶ Close the lever and check the stem is firmly in position.

### Checking the headset backlash

- ▶ To check the handlebar headset backlash, close the quick release lever on the stem. Place the fingers of one hand on the upper headset cup, pull the front wheel brake with the other hand and try to push the bicycle backwards and forwards.
- ▶ The headset cup halves must not move towards one another while you are doing this. Note that there may be noticeable backlash due to worn-out bearing bushes or brake lining backlash in suspension forks and disc brakes.
- ▶ If there is headset backlash in the steering headset, you must adjust it as soon as possible; otherwise, the headset will become damaged. You must make the adjustment as described in the stem manual.

### 5.3.5

#### Sale of the bicycle

- ▶ Fill out the data sheet on the first page of the operating instructions.
- ▶ Adjust the bicycle to the rider.
- ▶ Set the *stand* and the *shifter*, and show the purchaser the settings.
- ▶ Instruct the operator or rider how to use all the functions of the bicycle.

## 6

## Before the first ride

---



### Crash due to incorrectly adjusted torques

If a screw is fastened too tightly, it may break. If a screw is not fastened enough, it may loosen. This will result in a crash and injuries.

- ▶ Always observe the indicated torques on the screw or in the operating instructions.
- 

Only a correctly adjusted bicycle will guarantee you the desired ride comfort and health-promoting activity. Therefore adjust the *saddle*, the *handlebars* and the *suspension* to your body and your preferred riding style before the first ride.

### 6.1

### Adjusting the saddle

#### 6.1.1

#### Adjusting the saddle tilt

The saddle tilt must be adjusted to the seat height, the saddle and handlebar position, and the saddle shape to ensure an optimum fit. The seating position can be optimised in this way if needed. First, readjust the saddle after finding the handlebar position you prefer.

⇒ Place the saddle tilt in the horizontal position to adjust the bicycle to your needs for the first time.

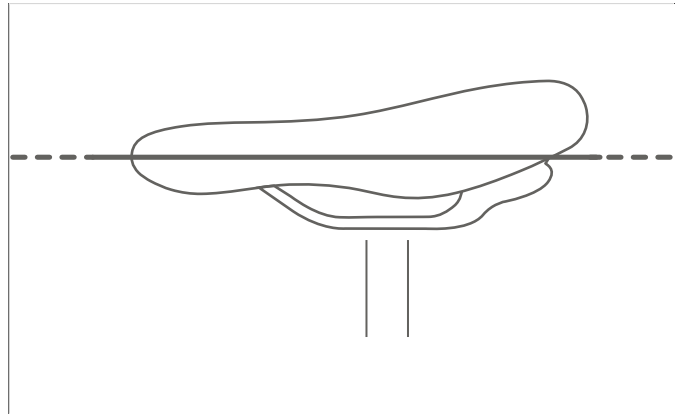

Figure 12:

Horizontal saddle tilt

## 6.1.2

### Determining the seat height

- ✓ To determine the seat height safely, either push the bicycle near to a wall, so that you can lean on the wall to support yourself or ask another person to hold the bicycle for you.
- ▶ Climb onto the bicycle.
- ▶ Place your heel on the pedal and extend your leg, so that the pedal is at the lowest crank rotation point.
- ⇒ The rider sits straight on the saddle if the seat is at an optimum height. If this is not the case, you can adjust the length of the seat post to your needs.

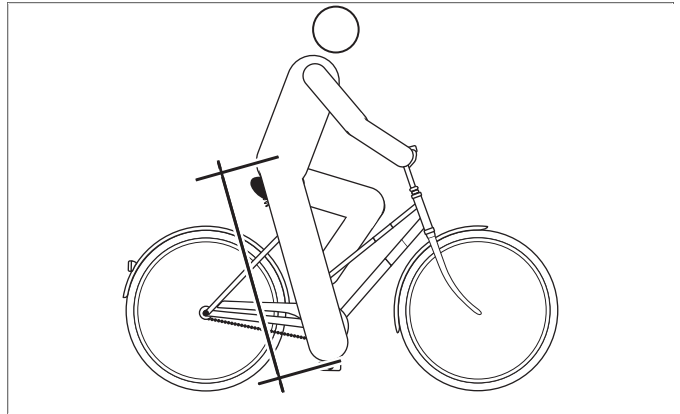

Figure 13: Optimal saddle height

### 6.1.3 Adjusting the seat height with quick release

- Open the quick release on the seat post to change the seat height. To do so, pull the clamping lever away from the seat post.

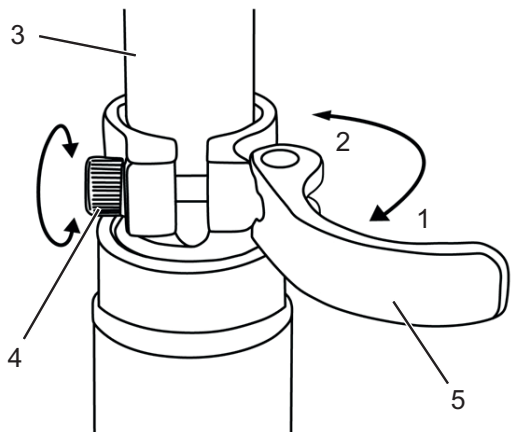

Figure 14: Seat post quick release (3) with clamping lever (5) and setting bolt (4) in the open position (1) and in the direction of the closed position (2)

- ▶ Set the seat post at the required height.



**Crash caused by an excessively high seat post setting**

A *seat post* with is set too high will cause the *seat post* or the *frame* to break. This will result in a crash and injuries.

- ▶ Do not pull the seat post out of the frame beyond the minimum insertion depth marking.

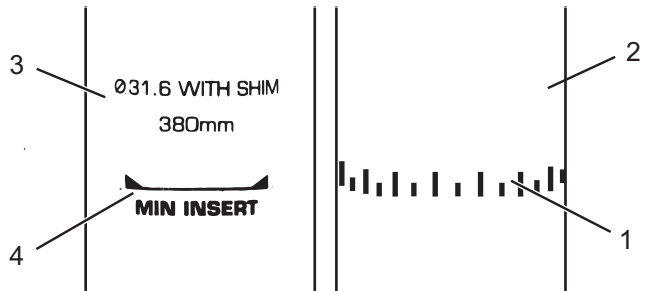

Figure 15:

**Detailed view of the seat post – examples of the minimum insertion depth marking**

- ▶ To close it, push the *seat post clamping lever* as far as it will go into the *seat post*.
- ▶ Check the *clamping force of the quick releases*.

## 6.1.4 Setting the height-adjustable seat post

- ▶ When using your seat post for the first time, you must give it a firm push downwards to set it in motion. This is due to the natural tendency of the seal to repel oil from the seal surface. You only need to do this before the first use or after a longer period of non-use. Once you have displaced the post through its deflection, the oil spreads on the seal and the post begins to function normally.

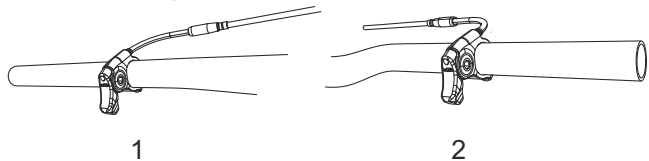

Figure 16: The seat post activation lever can be mounted either on the left (1) or the right (2) side of the handlebars

### 6.1.4.1 Lowering the saddle

- ✓ To lower the saddle, press your hand down on the saddle or sit on the saddle.
- ▶ Press the seat post activation lever and hold it down.
- ▶ Release the lever once you have reached the required height.

### 6.1.4.2 Raising the saddle

- ▶ Pull the seat post activation level.
- ▶ Remove any pressure on the saddle and release the lever once you have reached the required height.

## 6.1.5

### Adjusting the seat position

The saddle can be shifted on the saddle frame. The right horizontal position ensures an optimal leverage position for legs. This prevents knee pain and painful incorrect pelvis positions. If you have displaced the saddle more than 10 mm, you then need to adjust the saddle height again since both settings affect one another.

- ✓ To adjust the seat position safely, either push the bicycle near to a wall, so that you can lean on the wall to support yourself or ask another person to hold the bicycle for you.
- ▶ Climb onto the bicycle.
- ▶ Place the pedals into the vertical position (3 o'clock position) with your feet.
- ⇒ The rider is sitting in the optimal sitting position if the knee cap perpendicular line runs through the pedal axle. If the perpendicular line crosses behind the pedal, bring the saddle forward. If the perpendicular line crosses in front of the pedal, bring the saddle back. Move the saddle within its permitted displacement range only (marked on the saddle stay).

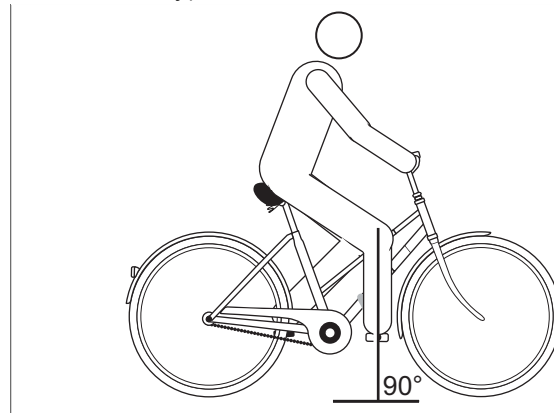

Figure 17:

Knee cap perpendicular line



## 6.2

## Setting the handlebars



- ✓ The handlebars must only be adjusted while the bicycle is stationary.
- ▶ Unfasten and adjust the designated screw connections, and clamp them with the maximum tightening torque for the clamping screws of the handlebars.

**Maximum tightening torque for the clamping screws of the handlebars\***

5 Nm - 7 Nm

\*if there is no other data on the component

Table 19:

**Handlebars clamping screw maximum tightening torque**

## Adjusting the stem



## Crash caused by loose stem

Incorrectly fastened screws may come loose due to impact. The stem may no longer be firmly fixed in its position as a result. This will result in a crash and injuries.

- ▶ Check the handlebars and the quick release system are firmly in position after the first two hours of riding.

## 6.2.1

### Adjusting the handlebar height



**CAUTION**

#### Crash caused by incorrectly set clamping force

Excessively high clamping force will damage the quick release and cause it to lose its function. Insufficient clamping force will cause a detrimental transmission of force. This can cause components to break. This will result in a crash and injuries.

- ▶ Never fasten a quick release using a tool (e.g. hammer or pliers).
- ▶ Only use the clamping lever with the specified set clamping force.

- ▶ Open the clamping lever.
- ▶ Pull the locking lever on the stem up, and simultaneously pivot the handlebars into the desired position.

⇒ You feel the locking lever click into place.

- ▶ Pull out the handlebars to the required height.
- ▶ Lock the quick release.

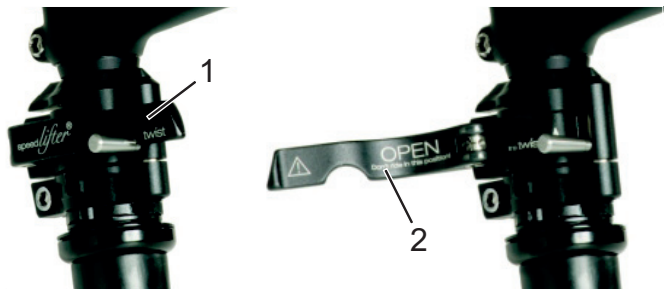

Figure 18:

Open (2) and closed (1) clamping lever on the stem – example: by.schulz speed lifter

## 6.2.2

### Turning the handlebars to the side *Alternative*



#### Crash caused by incorrectly set clamping force

Excessively high clamping force will damage the quick release and cause it to lose its function.

Insufficient clamping force will cause a detrimental transmission of force. This will result in a crash and injuries.

- ▶ Never fasten a quick release using a tool (e.g. hammer or pliers).
- ▶ Only use the clamping lever with the specified set clamping force.

- ▶ Open the clamping lever.
- ▶ Pull the locking lever on the stem up, and simultaneously pivot the handlebars into the desired position.

⇒ You feel the locking lever click into place.

- ▶ Pull out the handlebars to the required height.
- ▶ Lock the quick release.

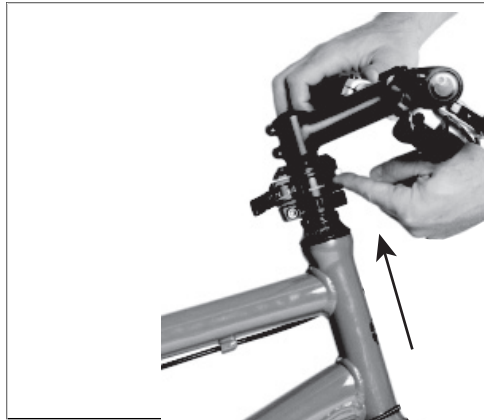

Figure 19:

Pulling locking lever upwards – example: by.schulz speed lifter

### 6.2.2.1

#### Checking the clamping force of the quick releases

- ▶ Open and close the quick releases on the stem or the seat post.
- ⇒ The clamping force is sufficient if the clamping lever can be moved easily from the open final position into the middle and has to be pressed with the fingers or base of the thumb from the middle point onwards.

### 6.2.2.2

#### Adjusting the quick release clamping force

- ▶ If the *clamping lever on the handlebars* cannot be moved into its final position, screw out the *knurled nut*.
- ▶ Tighten the *knurled nut* on the seat post if the *clamping lever's* clamping force is not sufficient.



If you are unable to set the clamping force, the specialist dealer will need to check the quick release.

## 6.3

### Adjusting the brake lever

#### 6.3.1

#### Adjusting the pressure point on a Magura brake lever



#### Brake failure due to incorrect setting

If the pressure point is set with brakes where the brake lining and brake disc have reached their wear limit, the brakes may fail and cause an accident with injury.

- ▶ Before you set the pressure point, ensure that the brake lining and brake disc have not reached their wear limit.

---

The pressure point setting is adjusted using the twist knob.

- ▶ Turn the twist knob towards the plus (+) symbol.

- ⇒ The brake lever moves closer to the handlebar grip. Re-adjust the grip distance as necessary.
- ⇒ The lever pressure point activates sooner.

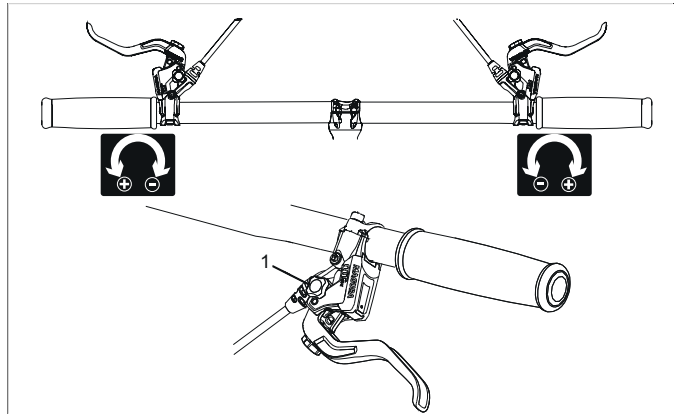

Figure 20:

Using the twist knob (1) to adjust the pressure point

### 6.3.2

## Adjusting the grip distance



### Crash caused by incorrectly set grip distance

If brake cylinders are set incorrectly or installed wrongly, the braking power may be lost at any time. Such damage may cause you to fall from the bicycle and injure yourself.

- ▶ Once the grip distance has been set, check the position of the brake cylinder and adjust it as necessary.
- ▶ Never correct the brake cylinder position without special tools. Have a specialist dealer correct it.



The brake lever grip distance can be adjusted to ensure that it can be reached more easily. Contact your specialist dealer if the brake handle is too far from the handlebars or is hard to use.

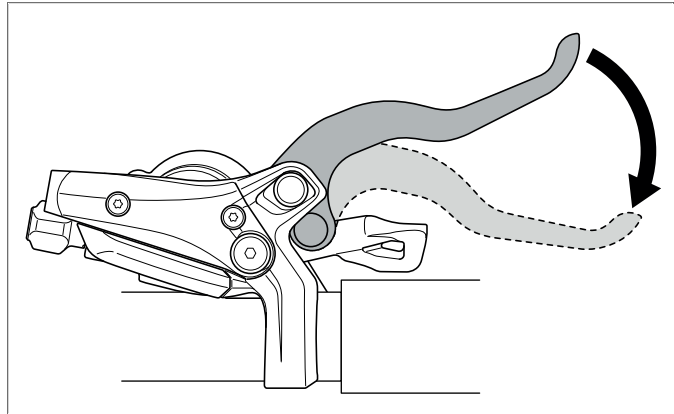

Figure 21: Brake lever grip distance

### 6.3.2.1 Adjusting the grip distance on a Magura brake lever (Alternative version)

Use a T25 TORX® wrench to turn the setting screw to adjust the grip distance.

- ▶ Turn the setting screw in the minus (-) direction.  
⇒ The brake lever moves closer to the handlebar grip.
- ▶ Turn the setting screw in the plus (+) direction.  
⇒ The brake lever moves away from the handlebar grip.

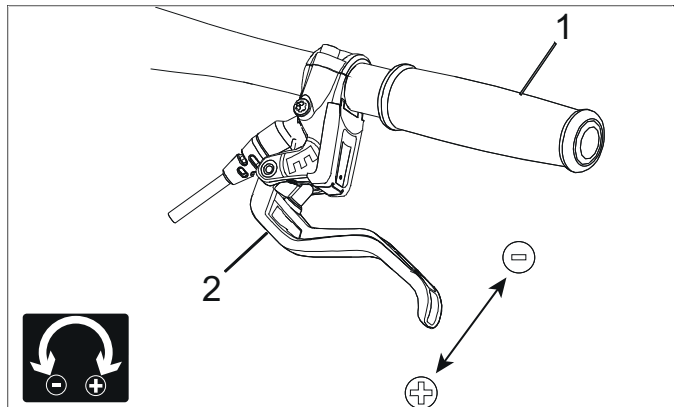

Figure 22: Using the setting screw (2) to adjust the distance from the brake lever to the handlebar grip (1)

## 6.4

### **Retracting brake linings**

New brake linings take time to break in and adjust to their final braking force.

- ▶ Accelerate bicycle to about 25 km/h.
- ▶ Brake bicycle until it comes to a halt
- ▶ Repeat process 30–50 times.
- ▶ The brake linings and brake discs are now broken in and provide optimal braking power.

# 7

## Operation

---



### Crash caused by loose clothing

Laces, scarves and other loose items may become entangled in the spokes on the *wheels* and the *chain drive*. Such damage may cause you to fall from the bicycle and injure yourself.

- ▶ Wear sturdy footwear and close-fitting clothing.
- 



### Crash caused by soiling

Heavy soiling can impair the functions of the bicycle, for example, the function of the brakes. Such damage may cause you to fall from the bicycle and injure yourself.

- ▶ Remove coarse soiling before riding.
- 



### Crash caused by poor road conditions

Loose objects, such as branches and twigs, may become caught in the wheels and cause a crash with injuries.

- ▶ Be aware of the road conditions.
  - ▶ Ride slowly and brake in good time.
- 



When riding downhill, high speeds may be reached. The bicycle is only engineered for exceeding a speed of 25 km/h briefly. In particular the *tyres* can fail if exposed to a continuous load.

- ▶ Decelerate the bicycle with the brakes if higher speeds than 25 km/h are reached.
- 



Heat or direct sunlight can cause the *tyre pressure* to increase above the permitted maximum pressure. This can destroy the *tyres*.

- ▶ Never park the bicycle in the sun.
  - ▶ On hot days, regularly check the *tyre pressure* and adjust it as necessary.
-



You can ride the bicycle within a temperature range between 5 °C and 35 °C. The effectiveness of the drive system is restricted outside of this temperature range.

---

**Operation temperature**

5 °C–35 °C

---

Moisture penetrating at low temperatures may impair individual bicycle functions due to the open structural design.

► Always keep the bicycle dry and free from frost.

► If the bicycle is to be used at temperatures below 3 °C, the specialist dealer must carry out an inspection and prepare the bicycle for winter usage first.



Off-road riding subjects the joints in the arms to severe strain. Take a break from riding every 30 to 90 minutes, depending on the condition of the roads.

## 7.1

### Before each ride

---



#### Crash caused by difficult-to-spot damage

If the bicycle topples over or you have a fall or an accident, there may be difficult-to-spot damage to components such as the brake system, quick releases or *frame*. Such damage may cause you to fall from the bicycle and injure yourself.

- ▶ Take the bicycle out of service and have a specialist dealer carry out an inspection.
- 



#### Crash caused by material fatigue

Intensive use can cause material fatigue. A component may suddenly fail in case of material fatigue. Such damage may cause you to fall from the bicycle and injure yourself.

- ▶ Remove the bicycle from service immediately in case of any signs of material fatigue. Have the specialist dealer check the state.
- ▶ Have the specialist dealer carry out a basic inspection regularly. During the inspection, the specialist dealer inspects the bicycle for any signs of material fatigue on the frame, fork, suspension element mountings (if there are any) and components made of composite materials.

Carbon becomes brittle when exposed to heat radiation such as heating. This can cause the carbon part to break and result in a crash with injuries.

- ▶ Never expose carbon parts to strong heat sources.
-

## 7.2

**Check list before each ride**

► Check the bicycle before each ride.

⇒ Do not use the bicycle if there are any anomalies.

<input type="checkbox"/>	Check that the bicycle is complete.
<input type="checkbox"/>	Check that the lighting, reflector and brake, for instance, are sufficiently clean.
<input type="checkbox"/>	You must check that the mudguards, the pannier rack and the chain guard are securely installed.
<input type="checkbox"/>	Check that the front and rear wheels run true. This is particularly important if the bicycle has been transported or secured with a lock.
<input type="checkbox"/>	Check the valves and the tyre pressure. Adjust as necessary before each ride.
<input type="checkbox"/>	If the bicycle has a hydraulic rim brake, check whether the locking levers are fully closed in their final positions.
<input type="checkbox"/>	Check the front and rear wheel brakes to make sure that they are working properly. To do so, operate the brake levers while stationary in order to check whether resistance is generated in the usual brake lever position. The brake must not lose any brake fluid.
<input type="checkbox"/>	Check that the driving light is working.
<input type="checkbox"/>	Check for unusual noises, vibrations, smells, staining, deformation, cracks, scores, abrasion and wear. This indicates material fatigue.
<input type="checkbox"/>	Inspect suspension system for cracks, dents, bumps, parts or leaking oil. Look at concealed sections on the bicycle's lower surfaces.
<input type="checkbox"/>	Use body weight to compress suspension system. If it feels too soft, adjust to the optimal "SAG" value.
<input type="checkbox"/>	If quick releases are used check them to make sure that they are fully closed in their end position. If quick release axle systems are used, make sure that all attachment screws are tightened to the correct torque.
<input type="checkbox"/>	Be alert to any unusual operating sensations when braking, pedalling or steering.

## 7.3

### Using the kickstand

---



#### Crash caused by a lowered kickstand

The kickstand does not fold up automatically. There is a risk of crashing if riding with the kickstand lowered.

- ▶ Raise the kickstand completely before the ride.
- 

#### NOTICE

The heavy weight of the bicycle may cause the kickstand to sink into soft ground and the bicycle may topple and crash over.

- ▶ The bicycle must be parked on firm, level ground only.
  - ▶ It is particularly important to check that the bicycle is stable if it is equipped with accessories or loaded with luggage.
- 

#### Raising the kickstand

- ▶ Before the ride, raise the kickstand completely with your foot.

#### Parking the bicycle

- ▶ Before parking, lower the kickstand completely with your foot.
- ▶ Park the bicycle carefully and check that it is stable.

## 7.4

**Battery****Risk of fire and explosion due to faulty battery**

The safety electronics on damaged or faulty batteries may fail. The residual voltage can cause a short circuit. The batteries may self-ignite and explode.

- ▶ Remove batteries with external damage from service immediately and never charge them.
- ▶ If the battery becomes deformed or begins to smoke, keep at a safe distance, disconnect the power supply at the socket, and notify the fire service immediately.
- ▶ Never extinguish damaged batteries with water or allow them to come into contact with water.
- ▶ If a battery is dropped or struck but shows no signs of external damage, remove the battery from service and observe it for at least 24 hours.
- ▶ Faulty batteries are hazardous goods. Dispose of faulty batteries properly and as quickly as possible.
- ▶ Store in a dry place until disposal. Never store in the vicinity of flammable substances.
- ▶ Never open or repair the battery.

**Risk of fire and explosion due to high temperatures**

Excessively high temperatures damage the battery. The battery may self-ignite and explode.

- ▶ Never expose the battery to sustained direct sunlight.



**CAUTION**

---

**Fire and explosion caused by short circuit**

Small metal objects may jumper the electrical connections of the battery. The batteries may self-ignite and explode.

- ▶ Keep paper clips, screws, coins, keys and other small parts away from the battery and do not insert them into the battery.



**CAUTION**

---

**Chemical burns to the skin and eyes caused by faulty battery**

Liquids and vapours may leak from damaged or faulty batteries. They can irritate the airways and cause burns.

- ▶ Avoid contact with leaked liquids.
- ▶ Immediately consult a doctor in case of contact with the eyes or any discomfort.
- ▶ In case of contact with the skin, rinse off immediately with water.
- ▶ Ventilate the room well.



**CAUTION**

---

**Fire and explosion caused by penetration by water**

The battery is only protected from simple spray water. Penetration by water can cause a short circuit. The battery may self-ignite and explode.

- ▶ Never immerse the battery in water.
  - ▶ If there is reason to believe that water may enter into the battery, the battery must be removed from service.
-

**NOTICE**

If a key is left inserted when transporting the bicycle or when riding, it may break off or the lock may open accidentally.

- ▶ Remove the key from the battery lock immediately after use.
- ▶ We recommend that you attach the key to a key ring.

**7.4.1****Integrated battery  
(Alternative version)**

- ✓ Before the battery is to be removed or inserted, switch off the battery and the drive system.

**7.4.1.1****Removing the integrated battery**

- ▶ Open the battery lock with the key.
- ▶ Pull the integrated battery out of the frame from below.
- ▶ Remove the key from the lock.

**7.4.1.2****Inserting the integrated battery**

- ▶ Place the battery with the contacts first into the mount above.
- ▶ Push the integrated battery downwards so that it audibly clicks into place.
- ▶ Use the key to fasten the battery lock.
- ▶ Remove the key.
- ▶ Check the inserted battery to make sure it is firmly in place.

## 7.4.2

### Charging the battery

---



#### Fire caused by overheated charger

The charger heats up when charging the battery. In case of insufficient cooling, this can result in fire or burns to the hands.

- ▶ Never use the charger on a highly flammable surface (e.g. paper, carpet etc.).
  - ▶ Never cover the charger during the charging process.
- 



#### Electric shock caused by penetration by water

If water penetrates into the charger, there is a risk of electric shock.

- ▶ Never charge the battery outdoors.
- 



#### Electric shock in case of damage

Damaged chargers, cables and plug connectors increase the risk of electric shock.

- ▶ Check the charger, cable and plug connector before each use. Never use a damaged charger.
  - ▶ The ambient temperature during the charging process must be within the range from 10 °C to 30 °C.
- 

**Charging temperature**

10 °C–30 °C

---

- ✓ The battery can remain on the bicycle or be removed for charging.
- ✓ Interrupting the charging process does not damage the battery.
- ✓ On a bicycle which is equipped with two batteries, the charging process for both batteries is started from the pannier rack battery.
- ▶ Remove the rubber cover from the battery.



- 
- ▶ Connect the mains plug of the charger to a normal domestic, grounded socket.

---

**Connection data**230 V, 50 Hz

---

- ▶ Connect the charging cable to the battery's charging port.
- ⇒ The charging process starts automatically.
- ⇒ During the charging process the operating and charge status indicator indicates the charge status. When the drive system is switched on, the *display* shows the charging process.
- ⇒ The charging process is complete when the LEDs of the operating and charge status indicator go out.

---

 **Risk of fire and explosion caused by damaged batteries.** The safety electronics on damaged or faulty batteries may fail. The residual voltage can cause a short circuit. The batteries may self-ignite and explode. If the battery becomes deformed or begins to smoke, keep at a safe distance, disconnect the power supply at the socket, and notify the fire service immediately. Never extinguish damaged batteries with water or allow them to come into contact with water.

---

 If an error occurs during the charging process, a system message is displayed. Remove the charger and the battery from operation immediately and follow the instructions.

---

### 7.4.3

#### **Waking the battery**

- ✓ When not used for a longer period, the battery switches to sleep mode for self-protection. The LEDs of the operating and charge status indicator do not light up.
- ▶ Press the *On-Off button (battery)*.
- ▶ The battery's operating and charge status indicator indicates the charge status.

## 7.5 Electric drive system

### 7.5.1 Switching on the drive system



#### Crash caused by lack of readiness for braking

When it is switched on, the drive system can be activated by the application of force on the pedals. There is a risk of a crash if the drive is activated unintentionally, and the brake is not reached.

- ▶ Never start the electric drive system, or switch it off immediately, if the brake cannot be reached safely and reliably.

---

- ✓ A sufficiently charged battery has been inserted on the bicycle.
- ✓ The battery is firmly in place. The key has been removed.
- ▶ Press and hold the **On-Off button** for 2 seconds.
- ⇒ 00 is shown on the display.
- ⇒ If the drive system is switched on, the drive is activated as soon as the pedals are moved with sufficient force.

### 7.5.2 Switching off the drive system

The system switches off automatically ten minutes after the last command. There is one option for switching off the drive system manually.

- ▶ Press and hold the **On-Off button** for 2 seconds.
- ⇒ The speed indicator goes out.

## 7.6 Operating element with display

### 7.6.1 Selecting the level of assistance

- ▶ Press the **up button**.
  - ⇒ The level of assistance is increased.
- ▶ Press the **down button**.
  - ⇒ The level of assistance is reduced.

## 7.7 Brakes

---



### Crash caused by incorrect use

Handling the brake improperly can lead to loss of control or crashes, which may result in injuries.

- ▶ Practise braking and emergency braking before the bicycle is used in public spaces.
- ▶ Shift your weight back and down as far as possible.



### Crash caused by wet conditions

The *tyres* may slip on wet roads. In wet conditions you must also expect a longer braking distance. The braking sensation differs from the usual sensation. This can cause loss of control or a crash, which may result in injuries.

- ▶ Ride slowly and brake in good time.



### Crash after cleaning, servicing or repair

The braking effect may be unusually weak temporarily after cleaning, servicing or repairing the bicycle. Such damage may cause you to fall from the bicycle and injure yourself.

- ▶ After cleaning, servicing or repair, carry out a few test brake applications.
-



---

### **Burns caused by heated brake**

The brakes may become very hot during operation. There is a risk of burns in case of contact.

- ▶ Never touch the components of the brake directly after the ride.

---

The drive force of the motor is shut off during the ride as soon as the rider no longer pedals. The drive system does not switch off when braking.

- ▶ In order to achieve optimum braking results, do not pedal while braking.

## **7.7.1**

### **Using the brake**

- ⇒ Pull the *brake levers* until the desired speed has been reached.

## 7.8

### Gear shift

The selection of the appropriate gear is a prerequisite for a physically comfortable ride and making sure that the electric drive system functions properly. The ideal pedalling frequency is between 70 and 80 revolutions per minute.

- ▶ It is advisable to stop pedalling briefly when changing gears. This makes it easier to switch gears and reduces wear on the drivetrain.

#### 7.8.1

#### Using derailleur gears

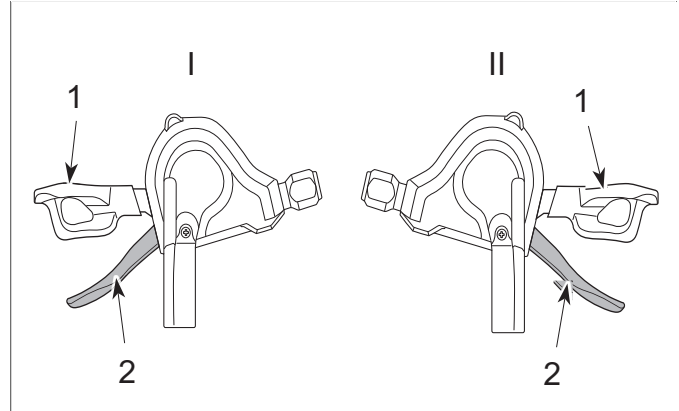

Figure 23:

**Down shifter (1) and up shifter (2) on the left (I) and right (II) shift**

- ▶ Select the appropriate gear with the *shifter*.
- ⇒ The gear shift switches the gear.
- ⇒ The shifter returns to its original position.
- ▶ Clean the rear derailleur if the gear change blocks.

## 7.9

**Brake****Hydraulic fluid can be fatal if it is swallowed and penetrates into the respiratory system**

Hydraulic fluid may leak out after an accident or due to material fatigue. Hydraulic fluid can be fatal if swallowed and inhaled.

**First aid treatment**

- ▶ Wear gloves and safety goggles as protective equipment. Keep unprotected persons away.
- ▶ Remove those affected from the danger area to fresh air. Never leave those affected unattended.
- ▶ Ensure sufficient ventilation.
- ▶ Immediately remove clothing items contaminated with hydraulic fluid.
- ▶ Serious slip hazard due to hydraulic fluid leakage.
- ▶ Keep away from naked flames, hot surfaces and sources of ignition.
- ▶ Avoid contact with skin and eyes.
- ▶ Do not inhale vapours or aerosols.

**After inhalation**

- ▶ Take in fresh air; consult doctor if any pain or discomfort.

**After skin contact**

- ▶ Wash affected skin with soap and water and rinse well. Remove contaminated clothing. Consult doctor if any pain or discomfort.

---

### **After contact with eyes**

- ▶ Rinse eyes under flowing water for at least ten minutes with the lids open; also rinse under lids. Consult eye doctor if pain or discomfort continues.

### **After ingestion**

- ▶ Rinse out mouth with water Never induce vomiting! Risk of aspiration!
- ▶ Place a person lying on their back who is vomiting in a stable recovery position on their side. Seek medical advice immediately.

### **Environmental protection measures**

- ▶ Never allow hydraulic fluid to flow into the sewage system, surface water or groundwater.
- ▶ Notify the relevant authorities if fluid penetrates the ground or pollutes water bodies or the sewage system.



---

### **Amputation due to rotating brake disc**

The brake disc in disc brakes is so sharp that it can cause serious injuries to fingers if they are inserted into the disc brake openings.

- ▶ Always keep fingers well away from the rotating brake disc.
-



**WARNING****Crash caused by brake failure**

Oil or lubricant on the brake disc in a disc brake or on the rim of a rim brake can cause the brake to fail completely. This may cause a crash with serious injuries as a consequence.

- ▶ Never allow oil or lubricant to come into contact with the brake disc or brake linings or on the rim of a rim brake.
- ▶ If the brake linings have come into contact with oil or lubricant, contact a dealer or a workshop to have the components cleaned or replaced.

If the brakes are applied continuously for a long time (e.g. while riding downhill for a long time), the fluid in the brake system may heat up. This may create a vapour bubble. This will cause air bubbles or any water contained in the brake system to expand. This may suddenly make the lever travel wider. This may cause a crash with serious injuries.

- ▶ Release the brake regularly when riding downhill for a longer period of time.

**CAUTION****Crash caused by wet conditions**

The *tyres* may slip on wet roads. In wet conditions you must also expect a longer braking distance. The braking sensation differs from the usual sensation. This can cause loss of control or a crash, which may result in injuries.

- ▶ Ride slowly and brake in good time.



---

### **Crash caused by incorrect use**

Handling the brake improperly can lead to loss of control or crashes, which may result in injuries.

- ▶ Shift your body weight back and down as far as possible.
- ▶ Practise braking and emergency braking before the bicycle is used in public spaces.
- ▶ Never use the bicycle if you can feel no resistance when pulling on the brake handle. Consult a specialist dealer.



---

### **Crash after cleaning or storage**

The brake system is not designed for use on a bicycle which is placed on its side or turned upside down. The brake may not function correctly as a result. This can cause a crash, which may result in injuries.

- ▶ If the bicycle is placed on its side or turned upside down, apply the brake a couple of times before setting off to ensure that it functions normally.
- ▶ Never use the bicycle if it no longer brakes as normal. Consult a specialist dealer.



---

### **Burns caused by heated brake**

The brakes may become very hot during operation. There is a risk of burns or fire in case of contact.

- ▶ Never touch the components of the brake directly after the ride.

---

The drive force of the motor is shut off during the ride as soon as the rider no longer pedals. The drive system does not switch off when braking.

- ▶ In order to achieve optimum braking results, do not pedal while braking.

## 7.9.1 Using the brake lever

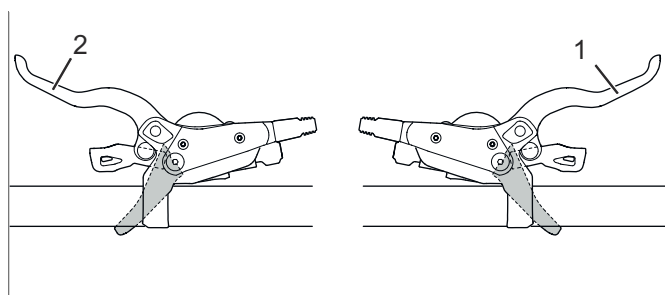

Figure 24: Front (2) and rear (1) brake lever – example: Shimano brake

- ▶ Pull the left *brake lever for the front wheel brake* and the right lever for the rear wheel brake until the desired speed is reached.

## 7.9.2 Using the back-pedal brake *Alternative*

- ✓ The best braking effect is achieved if the pedals are in the 3 o'clock and 9 o'clock position when braking. To bridge the free travel between the riding movement and the braking movement, it is recommendable to pedal a little beyond the 3 o'clock and 9 o'clock position before you pedal in the opposite direction to the *direction of travel* and start braking.
- ▶ Pedal in the opposite direction to the *direction of travel* until the desired speed has been reached.

## 8 Maintenance

### Cleaning check list

<input type="checkbox"/>	Clean pedals	after every ride
<input type="checkbox"/>	Clean suspension fork and, if necessary, rear frame damper	after every ride
<input type="checkbox"/>	Cleaning the battery	once a month
<input type="checkbox"/>	Chain (mainly tarmacked road)	every 250–300 km
<input type="checkbox"/>	Basic cleaning and preservation of all components	at least every six months
<input type="checkbox"/>	Clean the charger	at least every six months
<input type="checkbox"/>	Clean and lubricate height-adjustable seat post	every six months

### Maintenance check list

<input type="checkbox"/>	Check USB rubber cover position	before each ride
<input type="checkbox"/>	Check for tyre wear	once a week
<input type="checkbox"/>	Check for rim wear	once a week
<input type="checkbox"/>	Check the tyre pressure	once a week
<input type="checkbox"/>	Check brakes for wear	once a month
<input type="checkbox"/>	Check electrical cables and Bowden cables for damage and ensure they are fully functional	once a month
<input type="checkbox"/>	Check the chain tension	once a month
<input type="checkbox"/>	Check the tension of the spokes	every three months
<input type="checkbox"/>	Check the gear shift setting	every three months
<input type="checkbox"/>	Check suspension fork and, if necessary, rear frame damper for wear and ensure they are fully functional	every three months
<input type="checkbox"/>	Check for wear on brake discs	at least every six months

**Service check list**

<input type="checkbox"/>	Functional check on the suspension fork	Every 50 hours
<input type="checkbox"/>	Suspension fork maintenance and dismantling	Every 100 hours or at least every year
<input type="checkbox"/>	Complete maintenance of the rear frame damper	Every 125 hours
<input type="checkbox"/>	Inspection by the specialist dealer	every six months
<input type="checkbox"/>	Inspection of the drive unit	15,000 km

## 8.1 **Cleaning and servicing**

---



### **Crash and falling caused by unintentional activation**

There is a risk of injury if the drive system is activated unintentionally.

- ▶ Remove the battery before cleaning.

The following servicing measures must be performed regularly. Servicing can be performed by the operator and rider. In case of any doubt, consult the specialist dealer.

### 8.1.1 **After every ride**

#### 8.1.1.1 **Cleaning the suspension fork**

- ▶ Remove dirt and deposits on the stanchions and deflector seals with a damp cloth.
- ▶ Check the stanchions for dents, scratches, staining or leaking oil.
- ▶ Check the air pressure.
- ▶ Lubricate the dust seals and stanchions.

#### 8.1.1.2 **Cleaning the rear frame damper**

- ▶ Remove dirt and deposits from the damper body with a damp cloth.
- ▶ Check rear frame damper for dents, scratches, staining or leaking oil.

#### 8.1.1.3 **Cleaning the pedals**

- ▶ Clean with a brush and soapy water after riding through dirt or rain.
- ⇒ Service the pedals after cleaning.

## 8.1.2

**Basic cleaning****Crash caused by brake failure**

The braking effect may be unusually weak temporarily after cleaning, servicing or repairing the bicycle. Such damage may cause you to fall from the bicycle and injure yourself.

- ▶ Never apply care products or oil to the brake discs or brake linings, or the braking surfaces on the rims.
- ▶ After cleaning, servicing or repair, carry out a few test brake applications.

**NOTICE**

Water may enter into the inside of the bearings if you use a steam jet. The lubricant inside is diluted, the friction increases and, as a result, the bearings are destroyed in the long term.

- ▶ Never clean the bicycle with a steam jet.

**NOTICE**

Greased parts, e.g. the seat post, the handlebars or the stem, may no longer be safely and reliably clamped.

- ▶ Never apply grease or oil to the clamping areas.
- ✓ Remove battery and display before basic cleaning.

### 8.1.2.1

#### **Cleaning the frame**

- ▶ Soak the dirt stains on the frame with dish-washing detergent if the dirt is thick and ingrained.
- ▶ After leaving it to soak for a time, remove the dirt and mud with a sponge, brush and toothbrush.
- ▶ Use a watering can or your hand to rinse the frame to finish off.
- ▶ Service the frame after cleaning.

### 8.1.2.2

#### **Cleaning the stem**

- ▶ Clean stem with a cloth and washing water.
- ▶ Service the stem after cleaning.

### 8.1.2.3

#### **Cleaning the rear frame damper**

- ▶ Clean rear frame damper with a cloth and washing water.

### 8.1.2.4

#### **Cleaning the wheel**



---

#### **Crash due to braking hard on rim**

A rim can break and block the wheel if you brake hard. It may cause a crash with serious injuries.

- ▶ Check rim wear on a regular basis.
- 
- ▶ Check the tyres, rims, spokes and spoke nipples for any damage when cleaning the wheel.
  - ▶ Use a sponge and a brush to clean the hub and spokes from the inside to the outside.
  - ▶ Clean the rim with a sponge.



**8.1.2.5****Cleaning the drive elements**

- ▶ Spray the cassette, the chain wheels and the front derailleur with a degreasing agent.
- ▶ Clean coarse dirt with a brush after soaking for a short time.
- ▶ Wash down all parts with dish-washing detergent and a toothbrush.
- ▶ Service the drive elements after cleaning.

**8.1.2.6****Cleaning the chain****NOTICE**

- ▶ Never use aggressive (acid-based) cleaners, rust removers or degreasers when cleaning the chain.
  - ▶ Do not use chain cleaning devices or chain cleaning baths.
- 
- ▶ Slightly dampen a brush with dish-washing liquid. Brush both sides of the chain.
  - ▶ Dampen a cloth with dish-washing liquid. Place the cloth on the chain.
  - ▶ Hold with slight pressure while slowly turning the rear wheel, so the chain passes through the cloth.
  - ▶ If the chain is still dirty afterwards, clean it with WD40.
  - ▶ Service the chain after cleaning.

### 8.1.2.7

#### Cleaning the battery

---



#### Fire and explosion caused by penetration by water

The battery is only protected from simple spray water. Penetration by water can cause a short circuit. The battery may self-ignite and explode.

- ▶ Never clean the battery with a high-pressure water device, water jet or compressed air.
  - ▶ Never immerse the battery in water.
  - ▶ Never use cleaning agent.
  - ▶ Remove the battery from the bicycle before cleaning.
- 
- ▶ Only clean the electrical connections of the battery with a dry cloth or brush.
  - ▶ Wipe off the decorative sides with a damp cloth.

### 8.1.2.8

#### Cleaning the drive unit

---

#### NOTICE

If water enters into the drive unit, the unit will be permanently damaged.

- ▶ Never immerse the drive unit in water.
  - ▶ Never clean with a high-pressure water device, water jet or compressed air.
  - ▶ Never use cleaning agent.
- 
- ▶ Carefully clean the drive unit with a damp, soft cloth.

**8.1.2.9****Cleaning the display****NOTICE**

If water enters into the display, it will be permanently damaged.

- ▶ Never immerse the display in water.
  - ▶ Never clean with a high-pressure water device, water jet or compressed air.
  - ▶ Never use cleaning agent.
  - ▶ Remove the display from the bicycle before cleaning.
- 
- ▶ Carefully clean the display with a damp, soft cloth.

**8.1.2.10****Cleaning the brake****WARNING****Brake failure due to water penetration**

The brake seals are unable to withstand high pressures. Damaged brakes can fail and cause an accident with injury.

- ▶ Never clean the bicycle with a high-pressure water device or compressed air.
  - ▶ Take great care when using a hosepipe. Never point the water jet directly at the seal section.
- 
- ▶ Clean brake and brake discs with a brush, water and dish-washing detergent.
  - ▶ Clean brake discs thoroughly with brake cleaner or spirit.

### **8.1.3 Servicing**

#### **8.1.3.1 Servicing the frame**

- ▶ Dry frame after cleaning
- ▶ Spray with care oil Clean off the care oil again after a short time.

#### **8.1.3.2 Servicing the stem**

- ▶ Apply silicone or Teflon oil to the stem shaft tube and the quick release lever pivot point.
- ▶ If you have Speedlifter Twist, also apply oil to the unlocking bolt using the groove in the Speedlifter body.
- ▶ Apply a little acid-free lubricant grease between the stem quick release lever and the sliding piece to reduce the quick release lever operating force.

#### **8.1.3.3 Servicing the fork**

- ▶ Treat the dust seals with fork oil

#### **8.1.3.4 Servicing the drive elements**

- ▶ Spray the cassette, the chain wheels and the front derailleur with a degreasing agent.
- ▶ Clean coarse dirt with a brush after soaking for a short time.
- ▶ Wash down all parts with dish-washing detergent and a toothbrush.

#### **8.1.3.5 Servicing the pedal**

- ▶ Treat with spray oil after cleaning.

#### **8.1.3.6 Servicing the chain**

- ▶ Grease the chain thoroughly with chain oil after cleaning.

### 8.1.3.7

#### **Servicing the drive elements**

- ▶ Service Maintain front and rear derailleur articulated shafts and jockey wheels with Teflon spray.

## 8.2

## Maintenance

---



### CAUTION

### Crash and falling caused by unintentional activation

There is a risk of injury if the drive system is activated unintentionally.

- ▶ Remove the battery before maintenance.
- 

The following maintenance measures must be carried out regularly [▷ *Check list, page 84*]. They can be carried out by the operator and rider. In case of any doubt, consult the specialist dealer.

### 8.2.1

### Wheel

---



### WARNING

### Crash due to braking hard on rim

A rim can break and block the wheel if you brake hard. It may cause a crash with serious injuries.

- ▶ Check rim wear on a regular basis.
- 

### NOTICE

If the pressure is too low in the tyre, the tyre does not achieve its load bearing capacity. The tyre is not stable and may come off the rim.

If the pressure in the tyre is too high, the tyre may burst.

- ▶ Check the tyre pressure against the specifications [▷ *Data sheet, page 1*]
  - ▶ *Adjust the tyre pressure* as necessary.
- 
- ▶ Check the *tyre* wear.
  - ▶ Check the *tyre pressure*.
  - ▶ Check the *rims* for wear.
  - The rims of a rim brake with invisible wear indicator are worn as soon as the wear indicator becomes visible in the area of the rim joint.

- The rims with visible wear indicator are worn as soon as the black, all-round groove on the pad friction surface is no longer visible. We recommend that you also replace the *rims* with every second brake lining replacement.
- ▶ Check the tension of the spokes.

## 8.2.2

### Brake system



#### Crash due to brake failure

Worn brake discs and brake linings, as well as a lack of hydraulic fluid in the brake cable, reduce the braking power. Such damage may cause you to fall from the bicycle and injure yourself.

- ▶ Check the brake disc, brake linings and the hydraulic brake system on a regular basis and replace if necessary.
- 
- ▶ Replace the brake linings on the disc brake when the pad thickness has reached 0.5 mm.

## 8.2.3

### Electrical cables and brake cables

- ▶ Check all visible electrical cables and cables for damage. If, for example, the sheathing is compressed, the bicycle will need to be removed from service until the cables have been replaced.
- ▶ Check all electrical cables and cables to make sure they are fully functional.

## 8.2.4

### Gear shift

- ▶ Check the gear shift and the *shifter* or the *twist grip* setting and adjust it as necessary.

### 8.2.5

#### Stem

- ▶ The stem and quick release system should be inspected at regular intervals. The specialist dealer should adjust them if necessary.
- ▶ If the hexagon socket head screw is also loosened, the headset backlash also needs to be adjusted. Medium-strength thread locker, such as Loctite blue, then needs to be applied to the loosened screws and the screws tightened as per the instructions.
- ▶ Check for wear and signs of corrosion (maintain with an oily cloth) and for oil leaks.

### 8.2.6

#### Checking the chain and belt tension

#### NOTICE

---

Excessive chain or belt tension increases wear.

If the chain or belt tension is too low, there is a risk that the *chain* or belt will slip off the *chain wheels*.

- ▶ Check the chain and belt tension once a month.
- ▶ Check the chain or belt tension in three or four positions, turning the crank a full revolution.



- ▶ If the *chain* or the belt can be pushed more than 2 cm, you need to have the *chain* or belt tensioned again by the specialist dealer.
- ▶ If the *chain* or belt can only be pushed up and down less than 1 cm, you will need to slacken the *chain* or belt slightly.

⇒ The ideal chain or belt tension has been achieved if the *chain* or the belt can be pushed a maximum of 2 cm in the middle between the pinion and the toothed wheel. The crank must also turn without resistance.



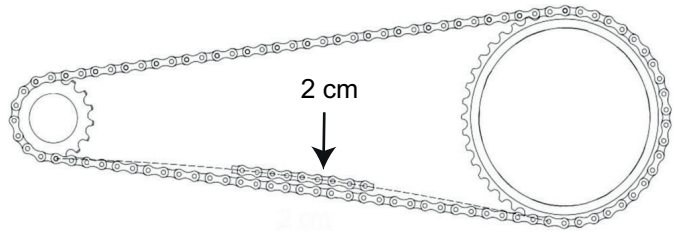

**Figure 25:** Checking the chain and belt tension



- ▶ If a hub gear is featured, the rear wheel must be pushed backwards or forwards to tighten the chain. This should be done by a specialist only.

### 8.2.7

#### USB port

#### NOTICE

Any moisture which enters through the USB port may trigger a short circuit in the *display*.

- ▶ Regularly check the position of the *cover on the USB port* and adjust it as necessary.

### 8.2.8

#### Suspension fork



- ▶ The specialist dealer will check the suspension fork function and the torques of attachment screws and nuts on the lower surfaces (steel: 10 Nm; alloy: 4 Nm). They will check the suspension fork for scratches, dents, cracks, stains, oil leaks or signs of wear or corrosion.

## 8.3

## Service

---



**CAUTION**

### **Crash and falling caused by unintentional activation**

There is a risk of injury if the drive system is activated unintentionally.

- ▶ Remove the battery before the service.
- 



**CAUTION**

### **Crash caused by material fatigue**

If the service life of a component has expired, the component may suddenly fail. Such damage may cause you to fall from the bicycle and injure yourself.

- ▶ Have the specialist dealer carry out six-monthly basic cleaning of the bicycle, preferably at the same time as the required servicing work.
- 

The specialist dealer must perform an inspection at least every six months. This is the only way to ensure that the bicycle remains safe and fully functional.



- ▶ The specialist dealer will inspect the bicycle for any signs of material fatigue during basic cleaning.
- ▶ The specialist dealer will check the software version of the drive system and update it. The electrical connections are checked, cleaned and preservative agent is applied. The electrical cables are inspected for damage.
- ▶ The specialist dealer will dismantle and clean the entire suspension fork interior and exterior. They will clean and lubricate the dust seals and slide bushings, check the torques and adjust the fork to the rider's preferred position. They will also replace the sliding collar if the clearance is too great (more than 1 mm on the fork bridge).



- ▶ The specialist dealer will fully inspect the interior and exterior of the rear frame damper, overhaul the rear frame damper, replace all air seals of air forks, overhaul the air suspension, change the oil and replace the dust wipers.
- ▶ The further servicing measures correspond to those which are recommended for a bicycle as per EN 4210. Particular attention is paid to the rim and brake wear. The spokes are re-tightened in accordance with the findings.

## 8.4

## Adjusting and repairing

---



### Crash and falling caused by unintentional activation

There is a risk of injury if the drive system is activated unintentionally.

- ▶ Remove the battery before the service.
- 

### 8.4.1

### Use original parts and lubricants only

The individual parts of the bicycle have been selected carefully and to matched to each other.

Only original parts and lubricants must be used for maintenance and repair.

The constantly updated lists of approved accessories and parts are available to specialist dealers.

## 8.4.2

**Wheel quick release**

---

**Crash caused by unfastened quick release**

A faulty or incorrectly installed quick release may become caught in the brake disc and block the wheel. This will cause a crash.

- ▶ Install the front wheel quick release lever on the opposite side to the brake disc.
- 

**Crash caused by faulty or incorrectly installed quick release**

The brake disc becomes very hot during operation. Parts of the quick release may become damaged as a result. The quick release comes loose. This will result in a crash and injuries.

- ▶ The front wheel quick release lever and the brake disc must be situated on opposite sides.
- 

**Crash caused by incorrectly set clamping force**

Excessively high clamping force will damage the quick release and cause it to lose its function.

Insufficient clamping force will cause a detrimental transmission of force. The suspension fork or the frame may break. This will result in a crash and injuries.

- ▶ Never fasten a quick release using a tool (e.g. hammer or pliers).
  - ▶ Only use the clamping lever with the specified set clamping force.
-

The clamping lever for the quick release is marked OPEN and CLOSE. If you can read the word OPEN, the quick release is open. If you can read the word CLOSE, the quick release is clamped.

⇒ The wheel clamping lever is clamped if the clamping lever can be moved easily from the open final position into the middle and has to be pressed with the fingers or base of the thumb from the middle point onwards.

#### 8.4.2.1

#### Clamping the quick release

▶ Hold the open clamping lever. Fasten the setting nut on the opposite side.

▶ Clamp the clamping lever.

⇒ The final position of the clamping lever is at a right angle to the fork or frame.

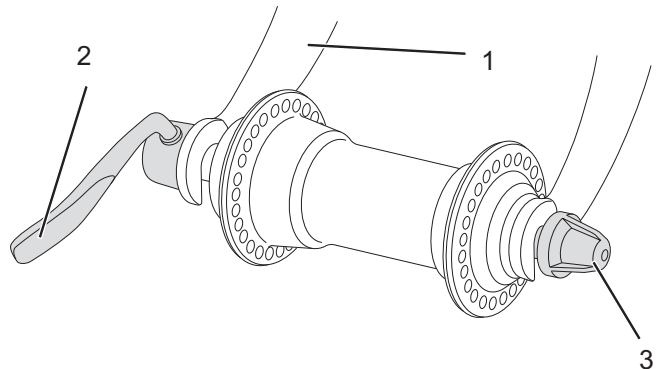

Figure 26:

**Wheel quick release, version I, with clamping lever (2), fork (1) and setting nut (3)**

**Checking and setting the clamping force of the quick releases**

If the clamping lever cannot be moved into its proper final position by pushing it with the hand, or if it is too loose, its clamping force will need to be readjusted.

- ▶ Open the clamping lever completely.
- ▶ Unfasten the setting nut a little.
- ▶ Clamp the clamping lever.
- ▶ If the clamping lever is not yet in the proper final position, repeat the steps until the proper final position has been achieved.

## 8.4.3

## Adjusting the tyre pressure

### 8.4.3.1

#### Dunlop valve

The tyre pressure cannot be measured on the simple Dunlop valve. The tyre pressure is therefore measured in the filling hose when pumping slowly with the bicycle pump.

- ✓ It is recommendable to use a bicycle pump with a pressure gauge. The operating instructions for the bicycle pump must be adhered to.
- ▶ Unscrew and remove the valve cap.
- ▶ Connect the bicycle pump.
- ▶ Pump up the tyre slowly and pay attention to the tyre pressure in the process.
- ⇒ The tyre pressure has been adjusted as per the data [[▶ Data sheet, page 1](#)].
- ▶ If the tyre pressure is too high, unfasten the union nut, let off air and tighten the union nut again.
- ▶ Remove the bicycle pump.
- ▶ Screw the valve cap tight.
- ✓ Screw the rim nut gently against the rim with the tips of your fingers.



Figure 27:

Dunlop valve with union nut (1) and rim nut (2)



## 8.4.3.2

**Presta valve**

- ✓ It is recommendable to use a bicycle pump with a pressure gauge. The operating instructions for the bicycle pump must be adhered to.
- ▶ Unscrew and remove the valve cap.
- ▶ Open the knurled nut around four turns.
- ▶ Carefully apply the bicycle pump so that the valve insert is not bent.
- ▶ Pump up the tyre slowly and pay attention to the tyre pressure in the process.
- ⇒ The tyre pressure has been adjusted as per the data [[Data sheet, page 1](#)].
- ▶ Remove the bicycle pump.
- ▶ Tighten the knurled nut with your finger tips.
- ▶ Screw the valve cap tight.
- ▶ Screw the rim nut gently against the rim with the tips of your fingers.

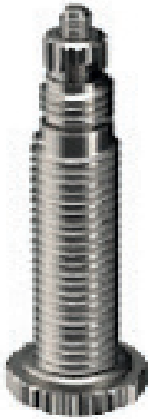

Figure 28:

**Presta valve with valve insert (1), knurled nut (2) and rim nut (3)**

### 8.4.3.3

#### Schrader valve

- ✓ It is recommendable to use a bicycle pump with a pressure gauge. The operating instructions for the bicycle pump must be adhered to.
- ▶ Unscrew and remove the valve cap.
- ▶ Connect the bicycle pump.
- ▶ Pump up the tyre slowly and pay attention to the tyre pressure in the process.
- ⇒ The tyre pressure has been adjusted as per the data [[▶ Data sheet, page 1](#)].
- ▶ Remove the bicycle pump.
- ▶ Screw the valve cap tight.
- ▶ Screw the rim nut gently against the rim with the tips of your fingers.



Figure 29:

Schrader valve with rim nut (1)

## 8.4.4

### First aid for system messages



#### Fire and explosion due to faulty batteries

The safety electronics on damaged or faulty batteries may fail. The residual voltage can cause a short circuit. The batteries may self-ignite and explode.

- ▶ Batteries with external damage must be removed from service immediately.
- ▶ Never allow damaged batteries to come into contact with water.
- ▶ If a battery is dropped or struck but shows no signs of external damage, remove the battery from service and observe it for at least 24 hours.
- ▶ Faulty batteries are hazardous goods. Dispose of faulty batteries properly and as quickly as possible.
- ▶ Store in a dry place until disposal. Never store in the vicinity of flammable substances.
- ▶ Never open or repair the battery.

The components of the drive system are checked constantly and automatically. If an error is detected, the respective error code appears on the *display*. The drive may be shut off automatically, depending on the type of error.

#### 8.4.4.1

##### First aid

If an error message is displayed, run through the following actions:

- ▶ Make a note of the system message.
- ▶ Shut off and re-start the drive system.
- ▶ If the system message is still displayed, remove and then re-insert the battery.

- ▶ Re-start the drive system.
- ▶ If the system message is still displayed, contact the KETTLER specialist dealer.

**8.4.4.2**

**Specific error eradication**

- ▶ Make a note of the system message.

<b>Error</b>	<b>Remedy</b>
10	▶ Charge the battery.
12	▶ Charge the battery.
24	Incorrect charger. ▶ Use the supplied charger for charging.
40, 41, 44	Overcurrent detected and motor overheating ▶ Relieve the motor with reduced pedalling or a lower assistance level.

**Table 20:**

**Error eradication using the code**

- ▶ If the system message is still displayed, contact the KETTLER specialist dealer.

## 8.5

**Accessories**

For bicycles without a kickstand we recommend a parking stand into which either the front or rear wheel can be inserted securely. The following accessories are recommended:

<i>Description</i>	<i>Article number</i>
Teddy child seat	08947-665
Flipper child seat	08947-660
Fitting stand	08981-880
Wall mount	08959-000
Ceiling mount	08959-500
Parking stand	08982-500
Messenger bag	08987-742
Layana shopping bag	08987-741
Pannier rack basket	08985-500
Smart bag	08987-745
Single bag	08987-746
Handlebar bag	08987-747
Smart Bag Waterproof	08987-748
Single Bag Waterproof	08987-749
Business bag	08987-744
Ladies' bag	08987-743

Table 21:

**Accessories**

\*System components are matched to the pannier rack and provide sufficient stability due to special transmission of force.

\*\*System components are matched to the drive system.

### 8.5.1

### Child seat

---

 **WARNING**

#### Crash due to incorrect child seat

Neither the pannier rack nor the bicycle down tube are suitable for child seats and may break. Such an incorrect position may cause a crash with serious injuries for the rider and the child.

- ▶ Never attach a child seat to the saddle, handlebars or down tube.
- 

 **CAUTION**

#### Crash caused by improper handling

When using child seats, the riding properties and the stability of the bicycle change considerably. This can cause a loss of control, a crash and injuries.

- ▶ You should practice how to use the child seat safely and reliably before using the bicycle in public spaces.
- 

 **CAUTION**

#### Risk of crushing due to exposed springs

The child may crush his/her fingers on exposed springs or open mechanical parts of the saddle or the seat post.

- ▶ Never install saddles with exposed springs if a child seat is being used.
  - ▶ Never install seat posts with suspension with open mechanical parts or exposed springs if a child seat is being used.
- 

**NOTICE**

- ▶ Observe the legal regulations on the use of child seats.
  - ▶ Observe the operating and safety notes for the child seat system.
  - ▶ Never exceed the total weight of the bicycle.
-



The specialist dealer will advise you on the choice of right child seat system for the child and the bicycle.

The specialist dealer must mount the child seat the first time to ensure that it is safely fitted.

When installing a child seat, the specialist dealer makes sure that the seat and the fastening mechanism for the seat are suitable for the bicycle and that all components are installed and firmly fastened. They will also ensure that shift cables, brake cables, hydraulic and electrical cables are adjusted as necessary, the rider's freedom of movement is not restricted and the bicycle's permitted total weight is not exceeded.

The specialist dealer will provide instruction on how to handle the bicycle and the child seat.

## 8.5.2

### Bicycle trailer



#### Crash caused by brake failure

The brake may not work sufficiently if there is an excessive trailer load. The long braking distance can cause a crash or an accident and injuries.

- ▶ Never exceed the specified trailer load.
- ▶ The operating and safety notes for the trailer system must be observed.
- ▶ The legal regulations on use of bicycle trailers must be observed.
- ▶ Only use type approved coupling systems.

#### NOTICE

A bicycle which is approved for towing a trailer is equipped with the respective information sign. Only bicycle trailers with a support load and total mass

which do not exceed the permitted values, must be used.

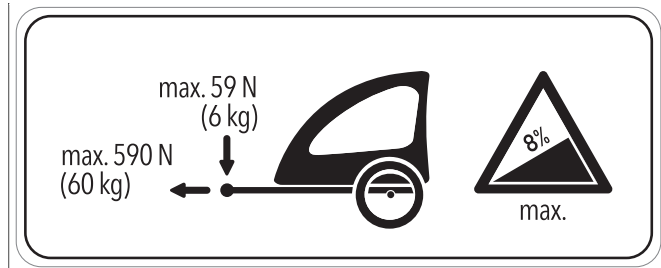

Figure 30:

Trailer sign



The specialist dealer will advise you on the choice of the right trailer system for the bicycle. The specialist dealer must install the trailer the first time to ensure that it is safely fitted.

### 8.5.3

#### Pannier rack



The specialist dealer will advise on choosing a suitable pannier rack.

The specialist dealer must mount the pannier rack the first time to ensure that it is safely fitted.

When installing a pannier rack, the specialist dealer makes sure that the rack and the fastening mechanism for the rack are suitable for the bicycle and that all components are installed and firmly fastened. They will also ensure that shift cables, brake cables, hydraulic and electrical cables are adjusted as necessary, the rider's freedom of movement is not restricted and the permitted total weight of the bicycle is not exceeded.

The specialist dealer will provide instruction on how to handle the bicycle and the pannier rack.



## 9

## Recycling and disposal

---

**WARNING****Risk of fire and explosion**

The safety electronics on damaged or faulty batteries may fail. The residual voltage can cause a short circuit. The batteries may self-ignite and explode.

- ▶ Remove batteries with external damage from service immediately and never charge them.
- ▶ If the battery becomes deformed or begins to smoke, keep at a safe distance, disconnect the power supply at the socket, and notify the fire service immediately.
- ▶ Never extinguish damaged batteries with water or allow them to come into contact with water.
- ▶ Faulty batteries are hazardous goods. Dispose of faulty batteries properly and as quickly as possible.
- ▶ Store in a dry place until disposal. Never store in the vicinity of flammable substances.
- ▶ Never open or repair the battery.

**CAUTION****Chemical burns to the skin and eyes**

Liquids and vapours may leak from damaged or faulty batteries. They can irritate the airways and cause burns.

- ▶ Avoid contact with leaked liquids.
  - ▶ Immediately consult a doctor in case of contact with the eyes or any discomfort.
  - ▶ In case of contact with the skin, rinse off immediately with water.
  - ▶ Ventilate the room well.
-



This device is marked according to the European Directive 2012/19/EU on waste electrical and electronic equipment – WEEE. The directive provides the framework for the return and recycling of used devices across the EU.



The bicycle, battery, display and charger are recyclable materials. You must dispose of and recycle them separately from domestic waste in compliance with the applicable statutory regulations.

Separate collection and recycling saves reserves of raw materials and ensures that all the regulations for protection of health and the environment are adhered to when recycling the product and/or the battery.

- ▶ Never dismantle the bicycle, battery or charger for disposal.
- ▶ The bicycle, display, the unopened and undamaged battery and the charger can be returned to any specialist dealer free of charge. Depending on the region, further disposal options may be available.
- ▶ Store the individual parts of the decommissioned bicycle in a dry place, free from frost, where they are protected from direct sunlight.

**10**  
**10.1****Appendix**  
**EC declaration of conformity****Translation of the original EC declaration of conformity**

The manufacturer:

KETTLER Alu-Rad GmbH  
Longericher Str. 2  
50739 Köln

hereby declares that the electrically power assisted cycles of types:

KU117-VAFDxx, KU117-VAFTxx, KU118-VAFDxx, KU118-VAFTxx, KU119-VAFDxx,  
KU119-VAFTxx, KU120-VAFDxx, KU120-VAFTxx, KU121-VAFDxx, KU159-VAKDxx,  
KU159-VAKTxx

year of manufacture 2018 and year of manufacture 2019,

comply with all applicable requirements of *Machinery Directive 2006/42/EC*. Furthermore,  
the electrically power assisted cycles comply with all applicable basic requirements of  
*Electromagnetic Compatibility Directive 2014/30/EU*.

The following standards were used: **EN ISO 12100:2010** Safety of machinery – General  
principles of design – Risk assessment and reduction, **EN 15194:2015**, Cycles – Electrically  
power assisted cycles – EPAC bicycles, **EN ISO 4210**, Cycles – Safety requirements for  
bicycles, **EN 11243:2016**, Cycles – Luggage carriers for bicycles – Requirements and test  
methods and **EN 82079 1:2012**, Preparation of instructions for use – Structuring, content and  
presentation – Part 1: General principles and detailed requirements.

Ms. Janine Otto (Technical Editor), c/o KETTLER Alu-Rad GmbH, Longericher Str. 2, 50739 Köln,  
is authorised to compile the technical documentation.



Cologne, 27/08/2018

.....

Place, date and signature

Egbert Hageböck  
-Managing Director-

## 10.2 Parts list

Model	2° E Beltdrive
Type number	KU117-VAFD50, KU117-VAFD55, KU117-VAFD60, KU117-VAFT45, KU117-VAFT50
Wheel size	28"
Drive	Belt drive
Motor	Suntour EBHM17; rear wheel hub motor
Gears	Shimano BR-MT200; hydraulic disc brake
Rechargeable battery	BMZ Evo Intube
Stem	Kalloy ML-2; monkeylink ready
Fork	Rigid fork, alloy
Seat post	Kalloy SP-368, patented post
Tyres	Schwalbe G-One; 40-622

**Table 22:** 2° E Beltdrive parts list

Model	2° E Street Beltdrive
Type number	KU118-VAFD50, KU118-VAFD55, KU118-VAFD60, KU118-VAFT45, KU118-VAFT50
Wheel size	28"
Drive	Belt drive
Motor	Suntour EBHM17; rear wheel hub motor
Gears	Single gear
Rechargeable battery	Shimano BR-MT200; hydraulic disc brake
Stem	BMZ Evo Intube
Fork	Kalloy ML-2; monkeylink ready
Seat post	Rigid fork, alloy
Tyres	Kalloy SP-368, patented post

**Table 23:** 2° E Street Beltdrive parts list

<b>Model</b>	<b>2° E Comp</b>
Type number	KU119-VAFD50, KU119-VAFD55, KU119-VAFD60, KU119-VAFT45, KU119-VAFT50
Wheel size	28"
Drive	Chain drive
Motor	Suntour EBHM17; rear wheel hub motor
Gears	Shimano Deore 9-gear derailleur
Rechargeable battery	Shimano BR-MT200; hydraulic disc brake
Stem	BMZ Evo Intube
Fork	Kalloy ML-2; monkeylink ready
Seat post	Rigid fork, alloy
Tyres	Kalloy SP-368, patented post
<b>Table 24:</b>	<b>2° E Comp parts list</b>

<b>Model</b>	<b>2° E Carbon</b>
Type number	KU120-VAFD50, KU120-VAFD55, KU120-VAFD60, KU120-VAFT45, KU120-VAFT50
Wheel size	28"
Drive	Belt drive
Motor	Suntour EBHM17; rear wheel hub motor
Gears	Single gear
Rechargeable battery	Shimano BR-MT200; hydraulic disc brake
Stem	BMZ Evo Intube
Fork	Kalloy ML-2; monkeylink ready
Seat post	Rigid fork, carbon
Tyres	SP-04 Carbon
<b>Table 25:</b>	<b>2° E Carbon parts list</b>

<b>Model</b>	<b>2° E Compact</b>
Type number	KU121-VAFD46
Wheel size	20"
Drive	Belt drive
Motor	Suntour EBHM17; rear wheel hub motor
Gears	Single gear
Rechargeable battery	Shimano BR-MT200; hydraulic disc brake
Stem	BMZ Evo Intube
Fork	Kalloy ML-2; monkeylink ready
Seat post	Rigid fork, alloy
Tyres	Kalloy SP-368, patented post

**Table 26: 2° E Compact parts list**

<b>Model</b>	<b>2° E Comp Street</b>
Type number	KU159-VAKD50, KU159-VAKD55, KU159-VAKD60, KU159-VAKT45, KU159-VAKT50
Wheel size	28"
Drive	Chain drive
Motor	Suntour EBHM17; rear wheel hub motor
Gears	Shimano Deore 9-gear derailleur
Rechargeable battery	Shimano BR-MT200; hydraulic disc brake
Stem	BMZ Evo Intube
Fork	Kalloy ML-2; monkeylink ready
Seat post	Rigid fork, alloy
Tyres	Kalloy SP-368, patented post

**Table 27: 2° E Comp Street parts list**

## 10.3 Table of figures

Figure 1:	Type plate, example, 17
Figure 2:	Bicycle viewed from the right, 2° E Beltdrive used as example, 24
Figure 3:	Detailed view of bicycle from rider position, example, 25
Figure 4:	Components of the wheel – example showing front wheel, 27
Figure 5:	Rim brake components with details – example: Magura HS22, 29
Figure 6:	<i>Rim brake locking lever</i> , closed (1) and open (2), 30
Figure 7:	Diagram of drive system, 31
Figure 8:	Diagram of electric drive system, 32
Figure 9:	Integrated battery details, 34
Figure 10:	Operating element overview, 35
Figure 11:	Fastening the transport securing device, 41
Figure 12:	Horizontal saddle tilt, 52
Figure 13:	Optimal saddle height, 53
Figure 14:	Seat post quick release (3) with clamping lever (5) and setting bolt (4) in the open position (1) and in the direction of the closed position (2), 53
Figure 15:	Detailed view of the seat post – examples of the minimum insertion depth marking, 54
Figure 16:	The seat post activation lever can be mounted either on the left (1) or the right (2) side of the handlebars, 55
Figure 17:	Knee cap perpendicular line, 56
Figure 18:	Open (2) and closed (1) clamping lever on the stem – example: by.schulz speed lifter, 58
Figure 19:	Pulling locking lever upwards – example: by.schulz speed lifter, 59
Figure 20:	Using the twist knob (1) to adjust the pressure point, 61
Figure 21:	Brake lever grip distance, 62
Figure 22:	Using the setting screw (2) to adjust the distance from the brake lever to the handlebar grip (1), 62
Figure 23:	Down shifter (1) and up shifter (2) on the left (I) and right (II) shift, 78
Figure 24:	Front (2) and rear (1) brake lever – example: Shimano brake, 83
Figure 25:	Checking the chain and belt tension, 97
Figure 26:	Wheel quick release, version I, with clamping lever (2), fork (1) and setting nut (3), 102

## Appendix

---

- Figure 27: Dunlop valve with union nut (1) and rim nut (2), 104  
Figure 28: Presta valve with valve insert (1), knurled nut (2) and rim nut (3), 105  
Figure 29: Schrader valve with rim nut (1), 106  
Figure 30: Trailer sign, 112



## 10.4 Subject index

### A

- Alternative equipment, 15
- Alternative version, 16
- Area of use, 14

### B

- Back-pedal brake,
  - braking, 83
- Battery, 34
  - charging, 72
  - checking, 48
  - disposing of, 115
  - eliminating charging errors, 107
  - removing, 71
  - waking, 74
- Belt tension, 96
- Bicycle type, 14
- Bike stand, see Kickstand
- Brake arm, 29
- Brake lever, 25
  - adjusting the pressure point 60

### Brake lining, 29

- maintaining, 95

### Brake,

- using the transport securing system, 41

### Break in operation, 42

- carrying out, 43
- preparing, 43

### Button,

- Plus, 35

### C

- Chain drive, 31
- Chain guard,
  - checking, 67
- Chain tension, 96
- Chain wheel, 31
- Chain, 24, 31
  - maintaining, 96
- Charge status indicator, 34
- Charger,
  - disposing of, 115

### D

- Data sheet, 1
- Direction of travel, 31

### Down tube battery,

- removing, 71

### Drive system, 31

- switching off, 75
- switching on, 75

### Driving light, 34

- checking function, 67

### E

#### EC declaration of conformity, 116

#### Error message, see System message,

### F

#### Fork, 27

- Fork end, 27

#### Frame number, 1

#### Frame, 24

#### Front wheel brake, 29

- braking, 77, 83

#### Front wheel, see Wheel

### G

#### Gear shift twist grip,

- checking, 95

#### Gear shift,

- maintaining, 95
- switching, 78

### H

#### Handlebars, 24, 25

#### Headlight, 24

#### Hub, 27

### I

#### Initial commissioning 46

### L

#### Level of assistance, 36

- selecting, 76

### M

#### Mass, see Weight

#### Minimum insertion depth

#### marking, 54

#### Model year, 17

#### Model, 1

#### Motor, 32

#### Mudguards,

- checking, 67

### O

#### Operating status indicator, 34

### P

#### Packaging, 45

#### Pannier rack, 24

- checking, 67

#### Parts list, 116

#### Pedal, 31

#### Plus button, 35

### R

#### Rim brake locking lever 30

#### Rim, 27

- checking, 94

#### Roller brake,

- braking, 83

### S

#### Saddle, 24

- changing the saddle tilt, 51

- changing the seat length, 56

- determining the saddle height, 52, 56

#### Seat post, 24

- clamping, 60, 61

#### Shifter,

- checking, 95
- setting, 98, 106

#### Spoke, 27

#### Storage, 41

#### Storing, see Storage

#### Suspension fork head, 27

#### Suspension fork, 28

#### System message, 36

- understanding, 107

### T

#### Transportation, 39

#### Transporting, see

#### Transportation

#### Type number, 1, 17

#### Tyre pressure, 1

#### Tyre size, 1

#### Tyres, 27

- checking, 94

### **V**

Valve, 27

Dunlop valve, 27

Presta valve, 27

Schrader valve, 27

### **W**

Weight,

permitted total weight, 17

Unladen weight, 1

Wheel circumference, 1

Wheel,

- maintaining, 94

Winter break, see break in operation

Working environment, 44

Text and images:  
ZEG Zweirad-Einkaufs-Genossenschaft eG  
Longericher Straße 2  
50739 Köln, Germany

Translation:  
Tanner Translations GmbH+Co  
Markenstraße 7  
40227 Düsseldorf, Germany

Operating instructions: 877-00136 • 1.0 • 13.09.2018

---

[www.kettler-alu-rad.de](http://www.kettler-alu-rad.de)

KETTLER Alu-Rad GmbH  
Longericher Straße 2  
50739 Köln, Germany

Tel.: +49 6805 6008 0

Fax: +49 6805 6008 3098

E-mail: [info@kettler-alu-rad.de](mailto:info@kettler-alu-rad.de)

**YOUR KETTLER SPECIALIST DEALER**

